

MODBUS Adapter

NA-9171 / 9173

(RS-232) (RS-485)

User Manual



Version 1.07

2013 CREVIS Co.,Ltd

DOCUMENT CHANGE SUMMARY				
REV	PAGE	REMARKS	DATE	EDITOR
1.0	New Document		2011/10/07	JE Kang
1.01	13	IO LED Status Flashing Red ↔ Red	2011/10/21	JE Kang
1.02	6	Add your experience	2012/1/13	JE Kang
1.03		Modify the wrong letters	2012/2/13	JE Kang
1.04		Changed Crevis TEL	2013/4/4	JE KANG
1.05		Environment Spec. 50°C→55°C (UL Temp)	2013/7/3	JE Kang
1.06	48	Trouble Shooting LED Status	2013/10/31	YM KIM
1.07		Modify the Pin Description	2014/05/08	YMKIM

CONTENTS

Trouble Shooting LED Status.....	2
1. Important Notes.....	6
1.1. Safety Instruction.....	7
1.1.1. Symbols.....	7
1.1.2. Safety Notes.....	7
1.1.3. Certification.....	7
2. Specification.....	8
2.1. The Interface.....	8
2.1.1. NA-9171(MODBUS RS-232).....	8
2.1.2. NA-9173 (MODBUS RS-485).....	9
2.2. Specification.....	10
2.2.1. General Specification.....	10
2.2.2. Interface Specification.....	11
2.3. LED Indicator.....	12
2.3.1. Module Status LED (MOD).....	12
2.3.2. Received Data LED (RXD).....	12
2.3.3. Transmit Data LED(TXD).....	12
2.3.4. Expansion Module Status LED (I/O).....	13
2.3.5. Field Power Status LED.....	13
3. Dimension.....	14
3.1. NA-9171.....	14
3.2. NA-9173.....	14
4. Mechanical Set Up.....	15

4.1.	Total Expansion.....	15
4.2.	Plugging and Removal of the Components.....	15
5.	MODBUS Electrical Interface.....	16
5.1.	FnBus System.....	16
5.2.	FnBus Pin Description.....	18
5.3.	MODBUS Electrical Interface.....	19
5.3.1.	NA-9171 (RS-232).....	19
5.3.2.	NA-9173 (RS-485).....	19
5.3.3.	Terminator Resistor.....	20
5.3.4.	MODBUS DIP Switch Setup.....	21
5.3.5.	MODBUS Address Setup.....	22
5.3.6.	I/O Process Image Map.....	23
5.3.7.	MODBUS Interface Register / Bit Map.....	23
5.4.	Example.....	24
5.4.1.	Example of Input Process Image(Input Register) Map.....	24
5.4.2.	Example of Output Process Image(Output Register) Map.....	27
6.	MODBUS INTERFACE.....	29
6.1.	MODBUS Transmission Mode.....	29
6.1.1.	RTU Transmission Mode.....	29
6.1.2.	ASCII Transmission Mode.....	29
6.2.	Supported MODBUS Function Codes.....	29
6.2.1.	1 (0x01) Read Coils.....	30
6.2.2.	2 (0x02) Read Discrete Inputs.....	31

6.2.3.	3 (0x03) Read Holding Registers	32
6.2.4.	4 (0x04) Read Input Registers.....	33
6.2.5.	5 (0x05) Write Single Coil	34
6.2.6.	6 (0x06) Write Single Register	35
6.2.7.	8 (0x08) Diagnostics	36
6.2.8.	15 (0x0F) Write Multiple Coils.....	38
6.2.9.	16 (0x10) Write Multiple Registers	39
6.2.10.	23 (0x17) Read/Write Multiple Registers	40
6.2.11.	Error Response.....	41
6.3.	MODBUS Special Register Map.....	42
6.3.1.	Adapter Identification Special Register (0x1000, 4096).....	42
6.3.2.	Adapter Watchdog Time, other Time Special Register (0x1020, 4128)	43
6.3.3.	Adapter Information Special Register (0x1100, 4352).....	44
6.3.4.	Expansion Slot Information Special Register (0x2000, 8192).....	45
6.4.	MODBUS Reference.....	47
7.	Trouble Shooting.....	48
7.1.	How to diagnose by LED indicator.....	48
APPENDIX A	50
A.1.	Product List.....	50
A.2.	Glossary.....	52

1. Important Notes

Solid state equipment has operational characteristics differing from those of electromechanical equipment. Safety Guidelines for the Application, Installation and Maintenance of Solid State Controls describes some important differences between solid state equipment and hard-wired electromechanical devices.

Because of this difference, and also because of the wide variety of uses for solid state equipment, all persons responsible for applying this equipment must satisfy themselves that each intended application of this equipment is acceptable.

In no event will CREVIS be responsible or liable for indirect or consequential damages resulting from the use or application of this equipment.

The examples and diagrams in this manual are included solely for illustrative purposes. Because of the many variables and requirements associated with any particular installation, CREVIS cannot assume responsibility or liability for actual use based on the examples and diagrams.

Warning!



- ✓ **If you don't follow the directions, it could cause a personal injury, damage to the equipment or explosion**
- Do not assemble the products and wire with power applied to the system. Else it may cause an electric arc, which can result into unexpected and potentially dangerous action by field devices. Arching is explosion risk in hazardous locations. Be sure that the area is non-hazardous or remove system power appropriately before assembling or wiring the modules.
- Do not touch any terminal blocks or IO modules when system is running. Else it may cause the unit to an electric shock or malfunction.
- Keep away from the strange metallic materials not related to the unit and wiring works should be controlled by the electric expert engineer. Else it may cause the unit to a fire, electric shock or malfunction.

Caution!

- ✓ **If you disobey the instructions, there may be possibility of personal injury, damage to equipment or explosion. Please follow below Instructions.**
- Check the rated voltage and terminal array before wiring. Avoid the circumstances over 55°C of temperature. Avoid placing it directly in the sunlight.
- Avoid the place under circumstances over 85% of humidity.
- Do not place Modules near by the inflammable material. Else it may cause a fire.
- Do not permit any vibration approaching it directly.
- Go through module specification carefully, ensure inputs, output connections are made with the specifications. Use standard cables for wiring.
- Use Product under pollution degree 2 environment.

1.1. Safety Instruction

1.1.1. Symbols

<p>DANGER</p> 	<p>Identifies information about practices or circumstances that can cause an explosion in a hazardous environment, which may lead to personal injury or death property damage or economic loss.</p>
<p>IMPORTANT</p>	<p>Identifies information that is critical for successful application and understanding of the product.</p>
<p>ATTENTION</p> 	<p>Identifies information about practices or circumstances that can lead to personal injury, property damage, or economic loss. Attentions help you to identify a hazard, avoid a hazard, and recognize the consequences.</p>

1.1.2. Safety Notes

<p>DANGER</p> 	<p>The modules are equipped with electronic components that may be destroyed by electrostatic discharge. When handling the modules, ensure that the environment (persons, workplace and packing) is well grounded. Avoid touching conductive components, e.g. FnBUS Pin.</p>
--	--

1.1.3. Certification

c-UL-us UL Listed Industrial Control Equipment, certified for U.S. and Canada

See UL File E235505

DNV CERTIFICATE No. A-10666 (NA-9173)

LR/FCC

CE Certificate

EN 61000-6-2; Industrial Immunity

EN 61000-6-4; Industrial Emissions

2. Specification

2.1. The Interface

2.1.1. NA-9171(MODBUS RS-232)

MODBUS Electrical Interface

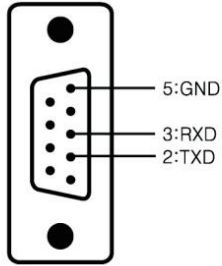

Dsub 9-Pin (Female)	SignalName	Description
1		
2	TXD	Output, Transmitted Data
3	RXD	Input, Received Data
4		
5	GND	Signal Common
6		
7		
8		
9		

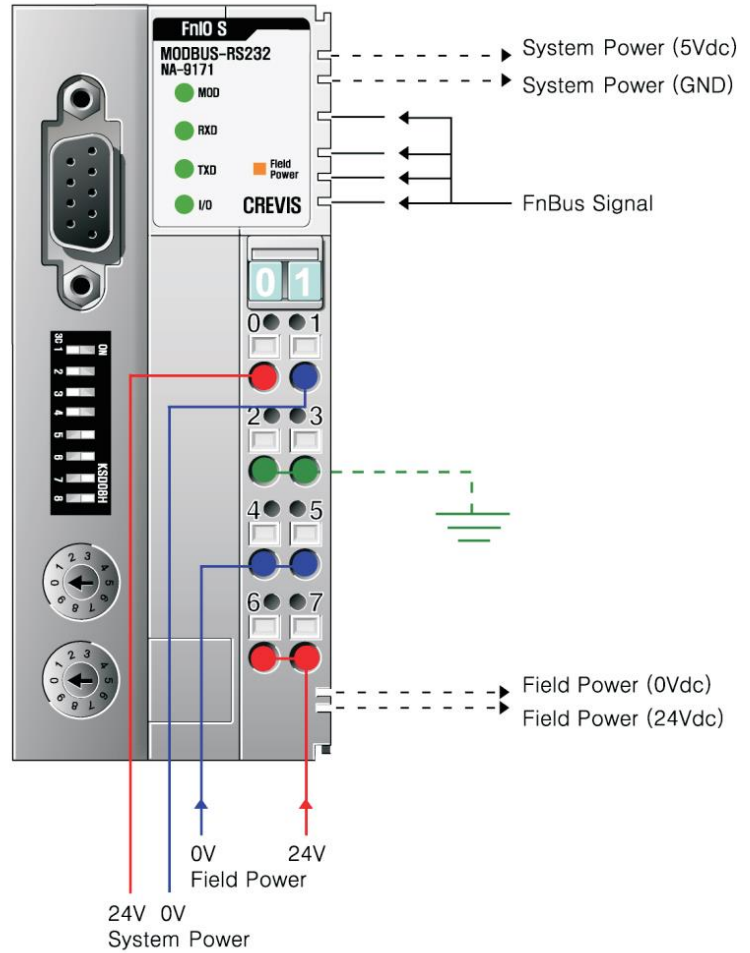

2.1.2. NA-9173 (MODBUS RS-485)

RS485 Connector

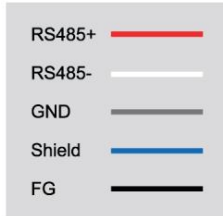

Dsub 5-Pin (Female)	SignalName	Description
1	RS485+	In/Out, Transceiver Data High
2	RS485-	In/Out, Transceiver Data Low
3	GND	Signal Common
4	Shield	Shield
5	FG	Frame Ground. Internally shorted with Shield

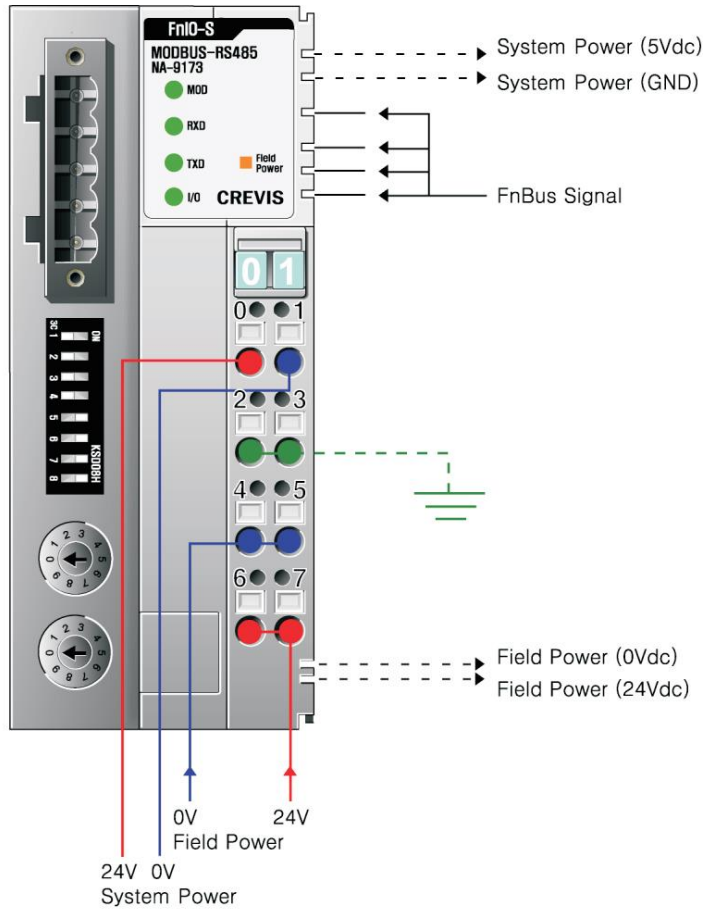

2.2. Specification

2.2.1. General Specification

General Specification	
System Power	Supply voltage : 24Vdc nominal Supply voltage range : 11~28.8Vdc Protection : Output current limit (Min. 1.5A) Reverse polarity protection
Power Dissipation	70mA typical @24Vdc
Current for I/O Module	1.5A @5Vdc
Isolation	System power to internal logic : Non-isolation System power to I/O driver : Isolation
Field Power	Supply voltage : 24Vdc nominal Supply voltage range : 11~28.8Vdc
Max. Current Field Power Contact	DC 10A Max.
Weight	150g
Module Size	45mm x 99mm x 70mm
Environment Condition	Refer to Environment Specification

Environmental Specifications	
Operating Temperature	-20 to 55℃
Non-Operating Temperature	-40℃ to 85℃
Relative Humidity	5%~90% non-condensing
Operating Altitude	2000m
Mounting	DIN rail

2.2.2. Interface Specification

Interface Specification, NA-9171(RS-232), NA-9173(RS-485)	
Adapter Type	Slave node (MODBUS Serial RTU/ASCII Server)
Max. Expansion Module	32 slots
Max. Input Size	126words (252bytes)
Max. Output Size	126words (252bytes)
Max. Length Bus Line	1200m (NA-9173, RS-485, depend on baud rate), 15m (NA-9171, RS-232)
Max. Nodes	64 nodes (NA-9173, RS-485), 1 node (NA-9171, RS-232)
Baud rate	1200, 2400, 4800, 9600, 19200, 38400, 57600, 115200bps
Protocol	RTU and ASCII
Interface Connector	5 Pin Open Connector (NA-9173, RS-485) Dsub 9pin (Female) (NA-9171, RS-232)
Settable Node Address	1~99 with two rotary switches
Indicator	5 LEDs 1 Green/Red, Module Status (MOD) 1 Green, Received Data (RXD) 1 Green, Transmit Data (TXD) 1 Green/Red Expansion Module Status (I/O) 1 Green, Field Power Status
Module Location	Starter module – left side of FnIO system
Field Power Detection	About 11Vdc

2.3. LED Indicator

2.3.1. Module Status LED (MOD)

State	LED is :	To indicate :
No Power	Off	No power is supplied to the unit.
Device Operational	Green	The unit is operating in normal condition.
Device in Standby	Flashing Green	The device needs commissioning due to configuration missing, incomplete or incorrect.
MODBUS Error	Green/Red Toggle	MODBUS error such as watchdog error, CRC/LRC error, Setup dip switch, error, etc.
Minor Fault	Flashing Red	Recoverable Fault - EEPROM sum check error.
Unrecoverable Fault	Red	The device has an unrecoverable fault. - Memory error or CPU watchdog error.

2.3.2. Received Data LED (RXD)

State	LED is :	To indicate :
Not Powered	Off	Device is not on-line or may not be powered
Adapter received correct message frame	Flashing Green	Adapter (Slave) received correct frame which address to the slave or broadcast. About 20msec flashing.

2.3.3. Transmit Data LED(TXD)

State	LED is :	To indicate :
Not Powered	Off	Device is not on-line or may not be powered
Adapter transmit frame	Flashing Green	Adapter (Slave) transmit frame. About 20msec flashing.

2.3.4. Expansion Module Status LED (I/O)

State	LED is :	To indicate :
Not Powered No Expansion Module	Off	Device has no expansion module or may not be powered
FnBus On-line, Do not Exchanging I/O	Flashing Green	FnBus is normal but does not exchanging I/O data (Passed the expansion module configuration).
FnBus Connection, Run Exchanging IO	Green	Exchanging I/O data
FnBus connection fault during exchanging IO	Red	One or more expansion module occurred in fault state. - Changed expansion module configuration. - FnBus communication failure.
Expansion Configuration Failed	Flashing Red	Failed to initialize expansion module - Detected invalid expansion module ID. - Overflowed Input / Output Size - Too many expansion module - Initial protocol failure - Mismatch vendor code between adapter and expansion module.

2.3.5. Field Power Status LED

State	LED is :	To indicate :
Not Supplied Field Power	Off	Not supplied 24V dc field power
Supplied Field Power	Green	Supplied 24V dc field power

3. Dimension

3.1. NA-9171

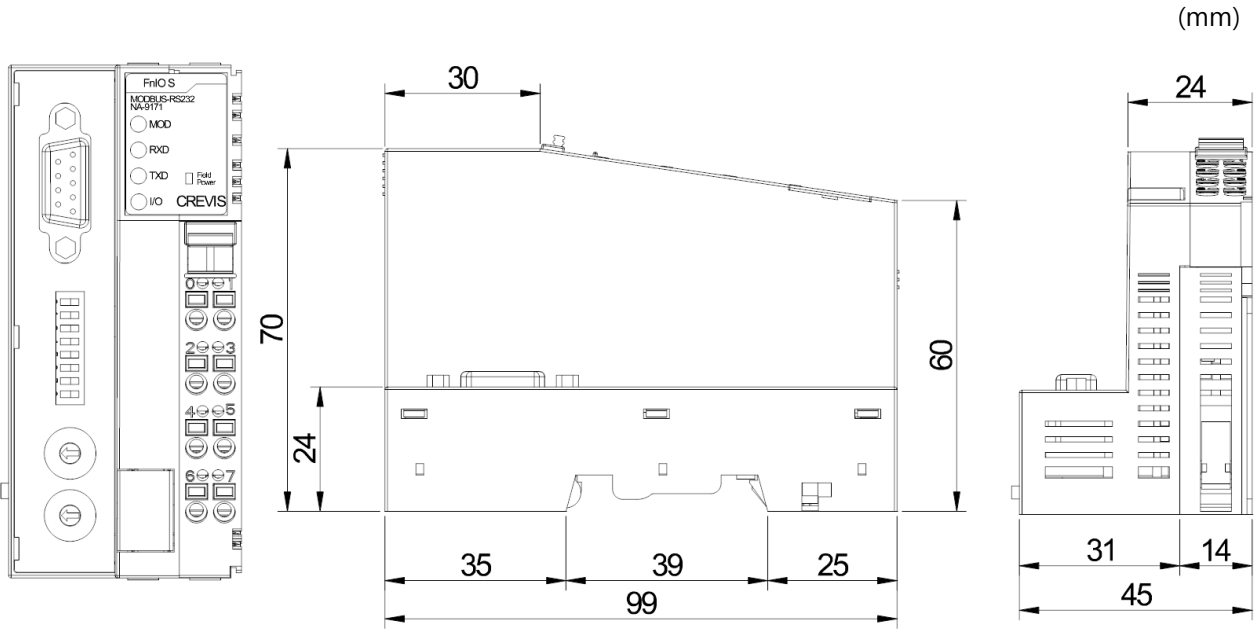

3.2. NA-9173

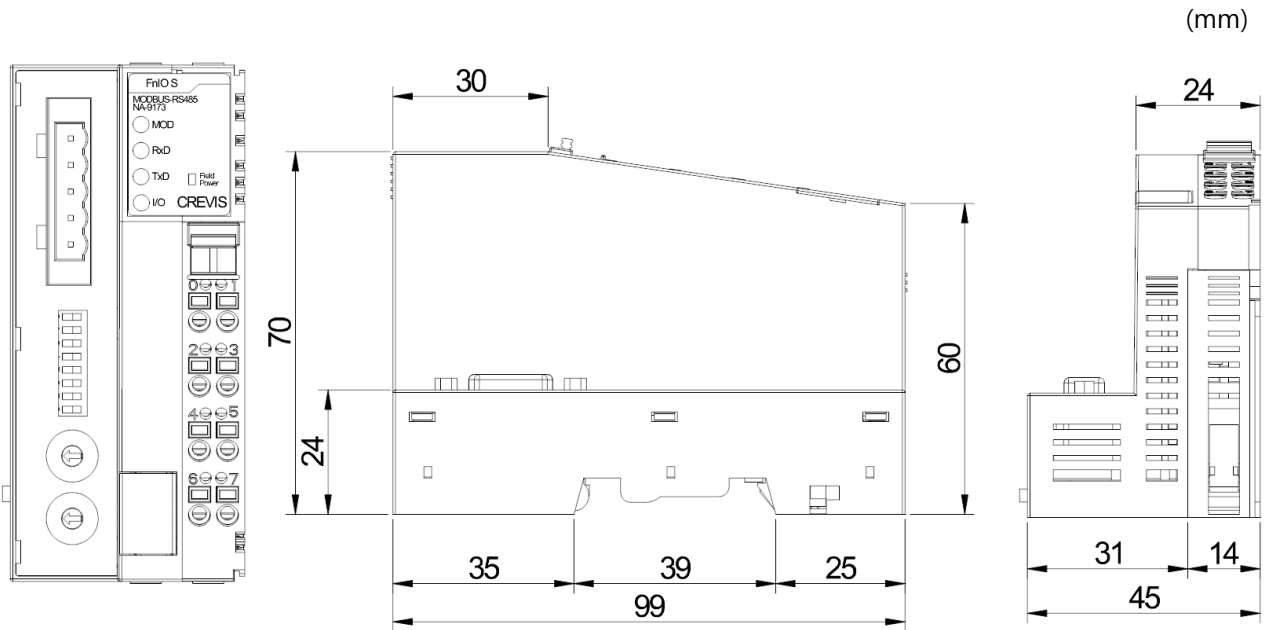

4. Mechanical Set Up

4.1. Total Expansion

The number of the module assembly that can be connected is 32. So the maximum length is 426mm Exception. ST-2748 is excepted to calculate maximum length because that is double width module.

4.2. Plugging and Removal of the Components.

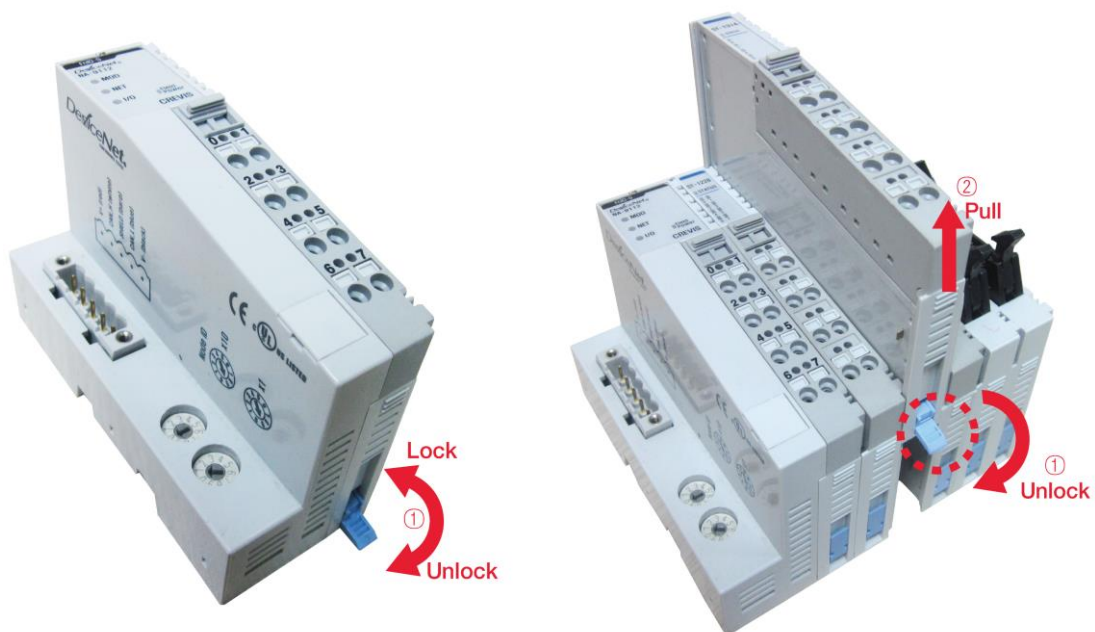

As above figure in order to safeguard the FnIO module from jamming, it should be fixed onto the DIN rail with locking level. To do so, fold on the upper of the locking lever.

To pull out the FnIO module, unfold the locking lever as below figure.

DANGER



Before work is done on the components, the voltage supply must be turned off.

5. MODBUS Electrical Interface

5.1. FnBus System

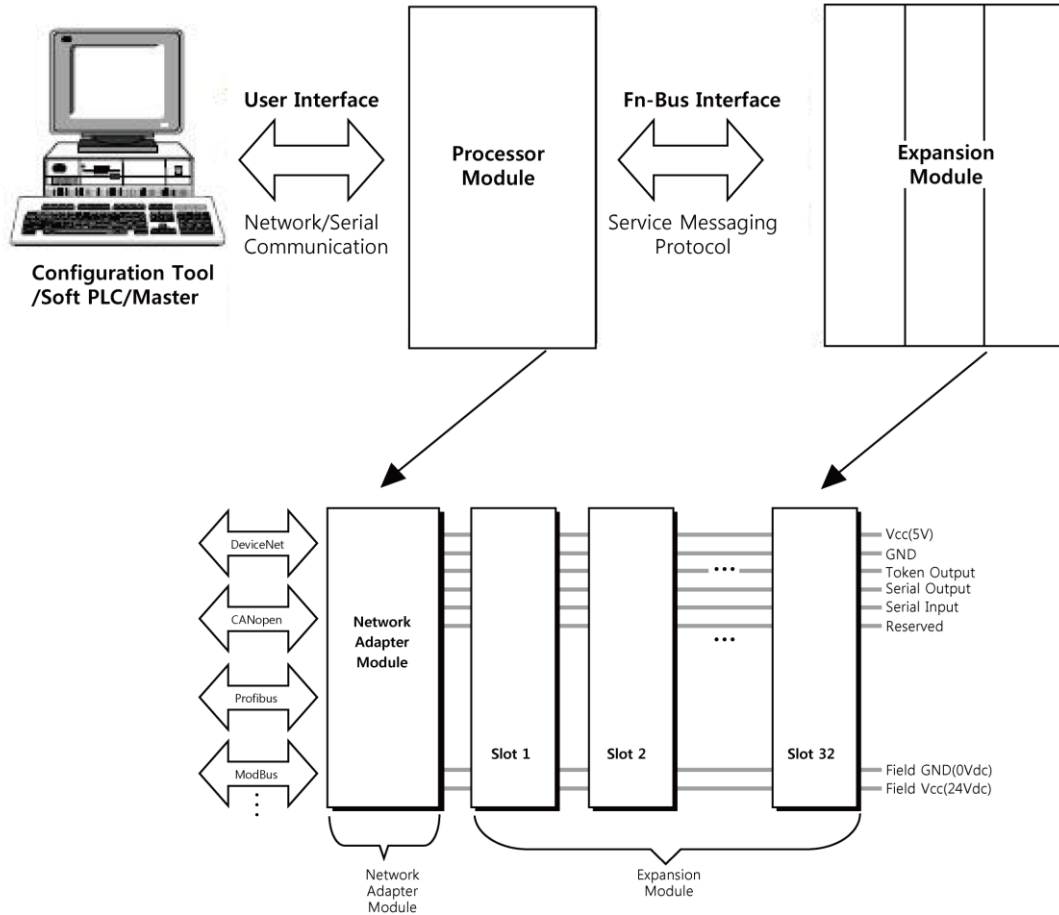

- **Network Adapter Module**

The Network Adapter Module forms the link between the field bus and the field devices with the Expansion Modules.

The connection to different field bus systems can be established by each of the corresponding Network Adapter Module, e.g. for SyncNet, PROFIBUS, CANopen, DeviceNet, Ethernet/IP, CC-Link, MODBUS/Serial, MODBUS/TCP etc.

- **Expansion Module**

The Expansion Modules are supported a variety of input and output field devices. There are digital and analog input/output modules and special function modules.

- **Two types of FnBus Message**

- Service Messaging
- I/O Messaging

5.2. FnBus Pin Description

Communication between the NA series and the expansion module as well as system / field power supply of the bus modules is carried out via the internal bus. It is comprised of 6 data pin and 2 field power pin.

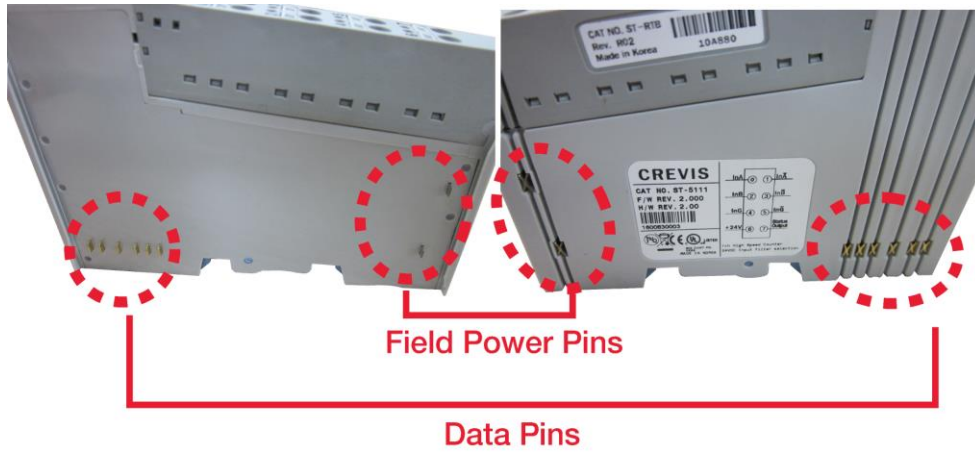

No.	Name	Description
1	Vcc	System supply voltage (5V dc).
2	GND	System Ground.
3	Token Output	Token output port of Processor module.
4	Serial Output	Transmitter output port of Processor module.
5	Serial Input	Receiver input port of Processor module.
6	Reserved	Reserved for bypass Token.
7	Field GND	Field Ground.
8	Field Vcc	Field supply voltage (24Vdc).

<p>DANGER</p> 	<p>Do not touch data and field power pins in order to avoid soiling and damage by ESD noise.</p>
--	--

5.3. MODBUS Electrical Interface

5.3.1. NA-9171 (RS-232)

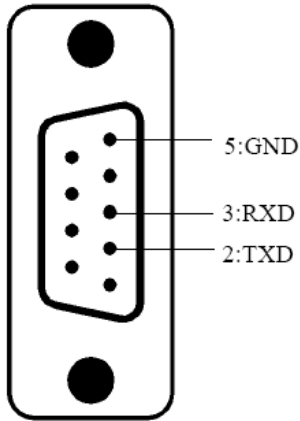

Dsub 9 (Female)	Signal Name	Description
1	-	
2	TXD	Output, Transmitted Data
3	RXD	Input, Received Data
4	-	
5	GND	Signal Common
6	-	
7	-	
8	-	
9	-	

5.3.2. NA-9173 (RS-485)

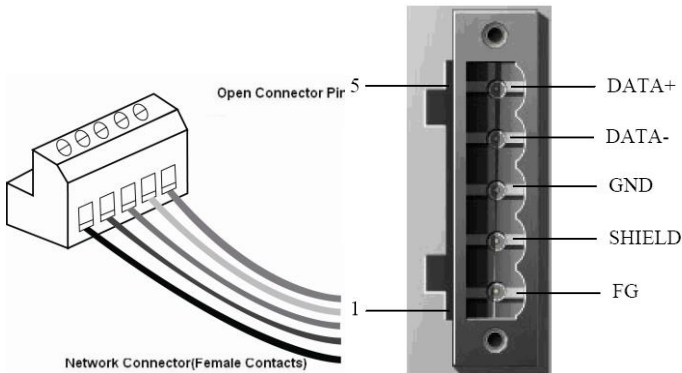

Male	Signal Name	Description
5	DATA +	In/Out, Transceiver Data High
4	DATA -	In/Out, Transceiver Data Low
3	GND	Signal Common
2	SHIELD	Internally Shorted
1	FG	

-3986-90102/Molex or 1862506/Phoenix
Compatible with DeviceNet 5-pin Open Connector

ATTENTION



The use of an incorrect supply voltage or frequency can cause severe damage to the component.

5.3.3. Terminator Resistor

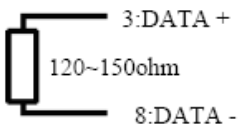
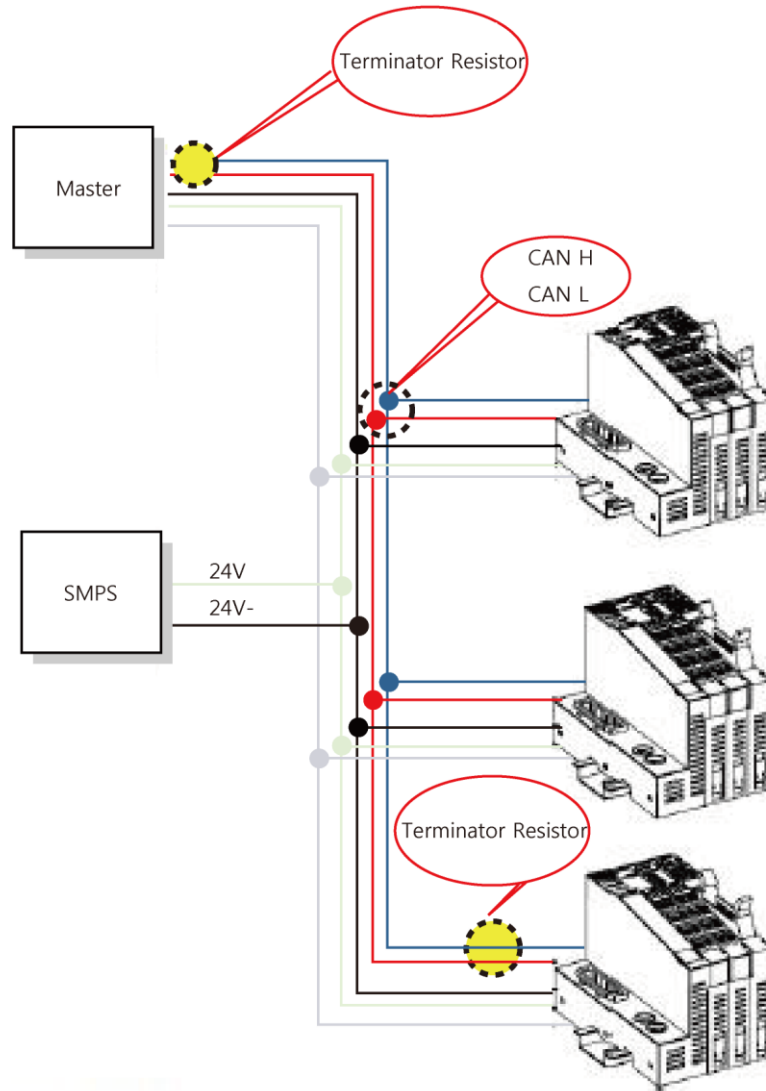

A reflection in a transmission line is the result of an impedance discontinuity that a traveling wave sees as it propagates down the line. To minimize the reflections from the end of the RS485-cable it is required to place a Line Termination near each of the 2 Ends of the Bus.

5.3.4. MODBUS DIP Switch Setup

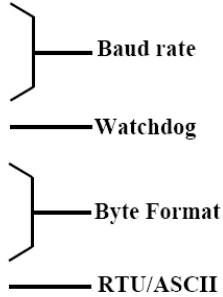
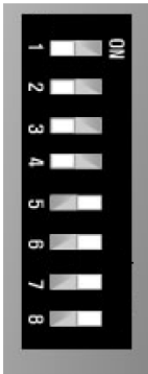

MODBUS Adapter interface configuration can be set by a DIP (8pole) switch. This setup read once at power-up sequence, i.e. changes to DIP switch during operation does not affect MODBUS interface configuration.

Item	Item setup	DIP Switch							
		#1	#2	#3	#4	#5	#6	#7	#8
Baud rate	1200 bps	OFF	OFF	OFF					
	2400 bps	ON	OFF	OFF					
	4800 bps	OFF	ON	OFF					
	9600 bps	ON	ON	OFF					
	19200 bps	OFF	OFF	ON					
	38400 bps	ON	OFF	ON					
	57600 bps	OFF	ON	ON					
	115200 bps	ON	ON	ON					
Watchdog	Disable Watchdog				OFF				
	Enable Watchdog				ON				
Byte Format	8 bit, No Party, 1 Stop					OFF	OFF	OFF	
	8 bit, Even Party, 1 Stop					ON	OFF	OFF	
	8 bit, Odd Party, 1 Stop					OFF	ON	OFF	
	8 bit, No Party, 2 Stop					ON	ON	OFF	
	7 bit, No Party, 2 Stop*					OFF	OFF	ON	
	7 bit, Even Party, 1 Stop*					ON	OFF	ON	
	7 bit, Odd Party, 1 Stop*					OFF	ON	ON	
	7 bit, No Party, 1 Stop*					ON	ON	ON	
RTU/ASCII Mode	RTU Mode								OFF
	ASCII Mode								ON

* ASCII Mode is not available.

5.3.5. MODBUS Address Setup

Each MODBUS Adapter could have a unique address (from 1 to 99) so that it can be addressed independently from other nodes. The address 0 is reserved to identify a broadcast exchange. No response is returned to broadcast requests sent by the master.

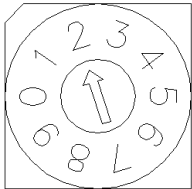

X 10 (MSD)

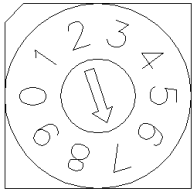

X 1 (LSD)

The above figure shows MAC ID 27(=2*10 + 7*1) of a slave node.

ATTENTION

MAC ID addresses have to be unique throughout the entire interconnected networks.

5.3.6. I/O Process Image Map

An expansion module may have 3 types of data as I/O data, configuration parameter and memory register. The data exchange between network adapter and expansion modules is done via an I/O process image data by FnBus protocol. The following figure shows the data flow of process image between network adapter and expansion modules.

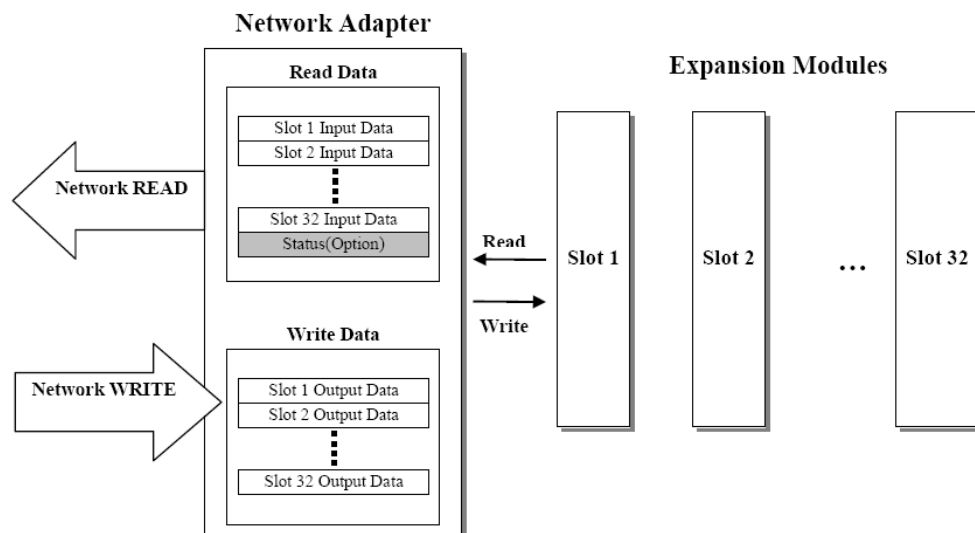

5.3.7. MODBUS Interface Register / Bit Map

- **Register Map**

Start Address	Read/Write	Description	Func. Code
0x0000 ~	Read	Process input image registers (Real Input Register)	4, 23
0x0800 ~	Read/Write	Process output image registers (Real Output Register)	3, 16, 23
0x1000 ~*	Read	Adapter Identification special registers.	3, 4, 23
0x1020 ~*	Read/Write	Adapter Watchdog, other time special register.	3, 4, 6, 16, 23
0x1100 ~*	Read/Write	Adapter Information special registers.	3, 4, 6, 16, 23
0x2000 ~*	Read/Write	Expansion Slot Information special registers.	3, 4, 6, 16, 23

* The special register map must be accessed by read/write of every each address (one address).

- **Bit Map**

Start Address	Read/Write	Description	Func. Code
0x0000 ~	Read	Process input image bits All input registers area is addressable by bit address. Size of input image bit is size of input image register * 16.	2
0x0800 ~	Read/Write	Process output image bits All output registers area is addressable by bit address. Size of output image bit is size of output image register * 16.	1, 5, 15

5.4. Example

5.4.1. Example of Input Process Image(Input Register) Map

Input image data depends on slot position and expansion slot data type. Input process image data is only ordered by expansion slot position when input image mode is uncompressed (mode 0, 2). But, when input image mode is compressed (mode 1, 3), input process image data is ordered by expansion slot position and slot data type. Input process image mode can be set by special register 0x1114(4372). Refer to 6.3.3.

● For example slot configuration

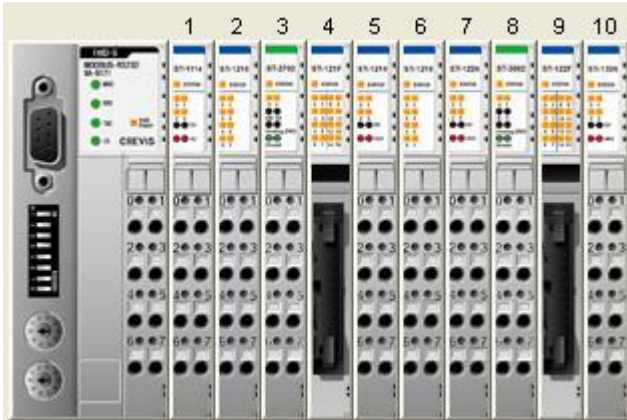

Slot Address	Module Description
#0	MODBUS Adapter
#1	4-discrete input
#2	8-discrete input
#3	2-analog input
#4	16-discrete input
#5	4-discrete input
#6	8-discrete input
#7	4-discrete input
#8	2-analog input
#9	16-discrete input
#10	4-discrete input

* After the system is reset, the new "Process Image Mode" action is applied.

● Input Process Image Mode#0 (Status(1 word) + Uncompressed Input Processing Data)

Status (1 word)

Addr.	#15	#14	#13	#12	#11	#10	#9	#8	#7	#6	#5	#4	#3	#2	#1	#0
0x0000	EW	EC	0	0	0	0	0	ES	FP	FnBus Status						
0x0001	Discrete In 8pts (Slot#2)								Empty, Always 0		Discrete In 4pts (Slot#1)					
0x0002	Analog Input Ch0 high byte (Slot#3)								Analog Input Ch0 low byte (Slot#3)							
0x0003	Analog Input Ch1 high byte (Slot#3)								Analog Input Ch1 low byte (Slot#3)							
0x0004	Discrete In high 8pts (Slot#4)								Discrete In low 8pts (Slot#4)							
0x0005	Discrete In 8pts (Slot#6)								Empty, Always 0		Discrete In 4pts (Slot#5)					
0x0006	Analog Input Ch0 low byte (Slot#8)								Empty, Always 0		Discrete In 4pts (Slot#7)					
0x0007	Analog Input Ch1 low byte (Slot#8)								Analog Input Ch0 high byte (Slot#8)							
0x0008	Discrete In low 8pts (Slot#9)								Analog Input Ch1 high byte (Slot#8)							
0x0009	Empty, Always 0				Discrete In 4pts (Slot#10)				Discrete In high 8pts (Slot#9)							

- ✓ **FnBus Status :**
 - 0: Normal Operation
 - 1: FnBus Standby
 - 2: FnBus Communication Fault
 - 3: Slot Configuration Failed
 - 4: No Expansion Slot
- ✓ **FP (Field Power) :**
 - 0: 24Vdc Field Power On.
 - 1: 24Vdc Field Power Off
- ✓ **ES (MODBUS Error Setup) :**
 - 0: No Error Setup
 - 1: Error Setup

✓ **EC (MODBUS Error Check) :**

0: No Error CRC/LRC

1: Error CRC/LRC three times more sequentially since its last restart, clear counters operation, or power-up.

✓ **EW (MODBUS Error Watchdog) :**

0: No Error Watchdog

1: Error Watchdog once more since its last restart, clear counters operation, or power-up.

● **Input Process Image Mode#1** (Status(1 word) + Compressed Input Processing Data)

Addr.	#15	#14	#13	#12	#11	#10	#9	#8	#7	#6	#5	#4	#3	#2	#1	#0
0x0000	EW	EC	0	0	0	0	0	ES	FP	FnBus Status						
0x0001	Analog Input Ch0 high byte (Slot#3)								Analog Input Ch0 low byte (Slot#3)							
0x0002	Analog Input Ch1 high byte (Slot#3)								Analog Input Ch1 low byte (Slot#3)							
0x0003	Analog Input Ch0 high byte (Slot#8)								Analog Input Ch0 low byte (Slot#8)							
0x0004	Analog Input Ch1 high byte (Slot#8)								Analog Input Ch1 low byte (Slot#8)							
0x0005	Discrete In low 8pts (Slot#4)								Discrete In 8pts (Slot#2)							
0x0006	Discrete In 8pts (Slot#6)								Discrete In high 8pts (Slot#4)							
0x0007	Discrete In high 8pts (Slot#9)								Discrete In low 8pts (Slot#9)							
0x0008	Discrete In 4pts (Slot#10)				Discrete In 4pts (Slot#7)				Discrete In 4pts (Slot#5)				Discrete In 4pts (Slot#1)			

✓ **Input Assembly Priority :**

- 1) Analog Input Data (Word type)
- 2) 8 or 16 points Discrete Input Data (Byte type)
- 3) 4 points Input Data (Bit type)
- 4) 2 points Input Data (Bit type)

● **Input Process Image Mode#2** (Uncompressed Input Processing Data without Status), **default input image**

Addr.	#15	#14	#13	#12	#11	#10	#9	#8	#7	#6	#5	#4	#3	#2	#1	#0
0x0000	Discrete In 8pts (Slot#2)								Empty, Always 0				Discrete In 4pts (Slot#1)			
0x0001	Analog Input Ch0 high byte (Slot#3)								Analog Input Ch0 low byte (Slot#3)							
0x0002	Analog Input Ch1 high byte (Slot#3)								Analog Input Ch1 low byte (Slot#3)							
0x0003	Discrete In high 8pts (Slot#4)								Discrete In low 8pts (Slot#4)							
0x0004	Discrete In 8pts (Slot#6)								Empty, Always 0				Discrete In 4pts (Slot#5)			
0x0005	Analog Input Ch0 low byte (Slot#8)								Empty, Always 0				Discrete In 4pts (Slot#7)			
0x0006	Analog Input Ch1 low byte (Slot#8)								Analog Input Ch0 high byte (Slot#8)							
0x0007	Discrete In low 8pts (Slot#9)								Analog Input Ch1 high byte (Slot#8)							
0x0008	Empty, Always 0				Discrete In 4pts (Slot#10)				Discrete In high 8pts (Slot#9)							

● **Input Process Image Mode#3** (Compressed Input Processing Data without Status)

Addr.	#15	#14	#13	#12	#11	#10	#9	#8	#7	#6	#5	#4	#3	#2	#1	#0
0x0000	Analog Input Ch0 high byte (Slot#3)								Analog Input Ch0 low byte (Slot#3)							
0x0001	Analog Input Ch1 high byte (Slot#3)								Analog Input Ch1 low byte (Slot#3)							
0x0002	Analog Input Ch0 high byte (Slot#8)								Analog Input Ch0 low byte (Slot#8)							
0x0003	Analog Input Ch1 high byte (Slot#8)								Analog Input Ch1 low byte (Slot#8)							
0x0004	Discrete In low 8pts (Slot#4)								Discrete In 8pts (Slot#2)							
0x0005	Discrete In 8pts (Slot#6)								Discrete In high 8pts (Slot#4)							
0x0006	Discrete In high 8pts (Slot#9)								Discrete In low 8pts (Slot#9)							
0x0007	Discrete In 4pts (Slot#10)				Discrete In 4pts (Slot#7)				Discrete In 4pts (Slot#5)				Discrete In 4pts (Slot#1)			

* FnBus uses the byte-oriented register mapping.

* Size of input image bit is size of input image register *16.

✓ **Input Assembly Priority :**

- 1) Analog Input Data (Word type)
- 2) 8 or 16 points Discrete Input Data (Byte type)
- 3) 4 points Input Data (Bit type)
- 4) 2 points Input Data (Bit type)

5.4.2. Example of Output Process Image(Output Register) Map

Output image data depends on slot position and expansion slot data type. Output process image data is only ordered by expansion slot position when output image mode is uncompressed (mode 0). But, when output image mode is compressed (mode 1), output process image data is ordered by expansion slot position and slot data type. Output process image mode can be set by special register 0x1115(4373). Refer to 6.3.3.

- For example slot configuration

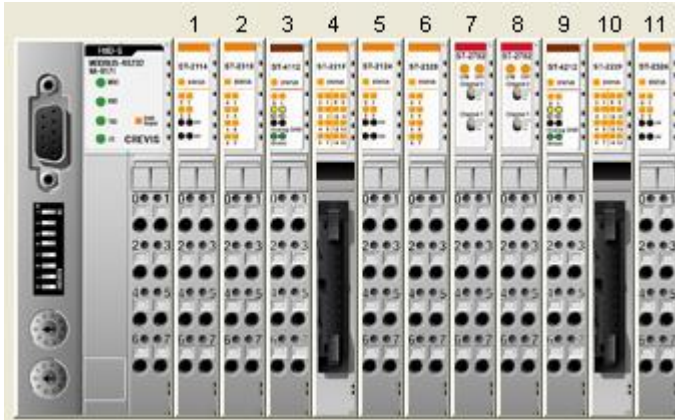

* After the system is reset, the new "Process Image Mode" action is applied.

Slot Address	Module Description
#0	MODBUS Adapter
#1	4-discrete output
#2	8-discrete output
#3	2-analog output
#4	16-discrete output
#5	4-discrete output
#6	8-discrete output
#7	2-relay output
#8	2-relay output
#9	2-analog output
#10	16-discrete output
#11	4-discrete output

- Output Process Image Mode#0 (Uncompressed Output Processing Data), default output image

Addr.	#15	#14	#13	#12	#11	#10	#9	#8	#7	#6	#5	#4	#3	#2	#1	#0
0x0800	Discrete out 8pts (Slot#2)								Empty, Don't care				Discrete out 4pts (Slot#1)			
0x0801	Analog out Ch0 high byte (Slot#3)								Analog out Ch0 low byte (Slot#3)							
0x0802	Analog out Ch1 high byte (Slot#3)								Analog out Ch1 low byte (Slot#3)							
0x0803	Discrete out high 8pts (Slot#4)								Discrete out low 8pts (Slot#4)							
0x0804	Discrete out 8pts (Slot#6)								Empty, Don't care				Discrete out 4pts (Slot#5)			
0x0805	Empty, Don't care							Discrete out 2pts (Slot#8)	Empty, Don't care							Discrete out 2pts (Slot#7)
0x0806	Analog out Ch0 high byte (Slot#9)								Analog out Ch0 low byte (Slot#9)							
0x0807	Analog out Ch1 high byte (Slot#9)								Analog out Ch1 low byte (Slot#9)							
0x0808	Discrete out high 8pts (Slot#10)								Discrete out low 8pts (Slot#10)							
0x0809	Empty, Don't care								Empty, Don't care				Discrete out 4pts (Slot#11)			

● **Output Process Image Mode#1** (Compressed Output Processing Data)

Addr.	#15	#14	#13	#12	#11	#10	#9	#8	#7	#6	#5	#4	#3	#2	#1	#0
0x0800	Analog out Ch0 high byte (Slot#3)								Analog out Ch0 low byte (Slot#3)							
0x0801	Analog out Ch1 high byte (Slot#3)								Analog out Ch1 low byte (Slot#3)							
0x0802	Analog out Ch0 high byte (Slot#9)								Analog out Ch0 low byte (Slot#9)							
0x0803	Analog out Ch1 high byte (Slot#9)								Analog out Ch1 low byte (Slot#9)							
0x0804	Discrete out low 8pts (Slot#4)								Discrete out 8pts (Slot#2)							
0x0805	Discrete out 8pts (Slot#6)								Discrete out high 8pts (Slot#4)							
0x0806	Discrete out high 8pts (Slot#10)								Discrete out low 8pts (Slot#10)							
0x0807	Discrete Out 2pts (Slot#8)		Discrete Out 2pts (Slot#7)		Discrete out 4pts (Slot#11)				Discrete out 4pts (Slot#5)				Discrete out 4pts (Slot#1)			

* FnBus uses the byte-oriented register mapping.

* Size of input image bit is size of input image register *16.

✓ **Output Assembly Priority :**

- 1) Analog Output Data (Word type)
- 2) 8 or 16 points Discrete Output Data (Byte type)
- 3) 4 points Output Data (Bit type)
- 4) 2 points Output Data (Bit type)

6. MODBUS INTERFACE

6.1. MODBUS Transmission Mode

Two different serial transmission modes are defined: The RTU mode and the ASCII mode. It defines the bit contents of message fields transmitted serially on the line. It determines how information is packed into the message fields and decoded.

6.1.1. RTU Transmission Mode

When devices communicate on a MODBUS serial line using the RTU (Remote Terminal Unit) mode, each 8-bit byte in a message contains two 4-bit hexadecimal characters. The main advantage of this mode is that its greater character density allows better data throughput than ASCII mode for the same baud rate. Each message must be transmitted in a continuous stream of characters.

Start	Address	Function	Data	CRC Check	End
≥ 3.5 chars	1 char	1 char	Up to 252 chars	2 chars	≥ 3.5 chars

6.1.2. ASCII Transmission Mode

When devices are setup to communicate on a MODBUS serial line using ASCII (American Standard Code for Information Interchange) mode, each 8-bit byte in a message is sent as two ASCII characters. This mode is used when the physical communication link or the capabilities of the device does not allow the conformance with RTU mode requirement regarding timers management.

Start	Address	Function	Data	CRC Check	End
1 char	2 chars	2 chars	Up to 252 chars	2 chars	2 chars CR,LF

6.2. Supported MODBUS Function Codes

Function Code	Function	Description	Unicast / Broadcast
1 (0x01)	Read Coils	Read output bit	Unicast
2 (0x02)	Read Discrete Inputs	Read input bit	Unicast
3 (0x03)	Read Holding Registers	Read output word	Unicast
4 (0x04)	Read Input Registers	Read input word	Unicast
5 (0x05)	Write Single Coil	Write one bit output	Unicast / Broadcast
6 (0x06)	Write Single Register	Write one word output	Unicast / Broadcast
8 (0x08)	Diagnostics (Serial Line only)	Read diagnostic register	Unicast
15 (0x0F)	Write Multiple Coils	Write a number of output bits	Unicast / Broadcast
16 (0x10)	Write Multiple registers	Write a number of output words	Unicast / Broadcast
23 (0x17)	Read / Write Multiple register	Read a number of input words / Write a number of output words	Unicast

- Refer to MODBUS APPLICATION PROTOCOL SPECIFICATION V1.1a

6.2.1. 1 (0x01) Read Coils

This function code is used to read from 1 to 2000 contiguous status of coils in a remote device. The Request PDU specifies the starting address, i.e. the address of the first coil specified, and the number of coils. In the PDU Coils are addressed starting at zero. Therefore coils numbered 1-16 are addressed as 0-15. The coils in the response message are packed as one coil per bit of the data field. Status is indicated as 1= ON and 0= OFF.

● Request

Field name	Example	RTU	ASCII	ASCII (bus line)
Start of Frame	-	t1-t2-t3	“,”	0x3A
Slave Address	0x07	0x07	“07”	0x30, 0x37
Function Code	0x01	0x01	“01”	0x30, 0x31
Starting Address Hi	0x10	0x10	“10”	0x31, 0x30
Starting Address Lo	0x00	0x00	“00”	0x30, 0x30
Quantity of Outputs Hi	0x00	0x00	“00”	0x30, 0x30
Quantity of Outputs Lo	0x0A	0x0A	“0A”	0x30, 0x41
Error Check (CRC/LRC)	-	0xB8, 0xAB	“DE”	0x44, 0x45
End of Frame	-	t1-t2-t3	CR, LF	0x0D, 0xA

● Response

Field name	Example	RTU	ASCII	ASCII (bus line)
Start of Frame	-	t1-t2-t3	“,”	0x3A
Slave Address	0x07	0x07	“07”	0x30, 0x37
Function Code	0x01	0x01	“01”	0x30, 0x31
Byte Count	0x02	0x02	“02”	0x30, 0x32
Output Status	0x55	0x55	“55”	0x35, 0x35
Output Status	0x02	0x02	“02”	0x30, 0x32
Error Check (CRC/LRC)	-	0x8F, 0x6D	“9F”	0x39, 0x46
End of Frame	-	t1-t2-t3	CR, LF	0x0D, 0xA

* In case of address 0x1015~0x1000 output bit value: 00000010_01010101.

6.2.2. 2 (0x02) Read Discrete Inputs

This function code is used to read from 1 to 2000 contiguous status of discrete inputs in a remote device. The Request PDU specifies the starting address, i.e. the address of the first input specified, and the number of inputs. In the PDU Discrete Inputs are addressed starting at zero. Therefore Discrete inputs numbered 1-16 are addressed as 0-15. The discrete inputs in the response message are packed as one input per bit of the data field. Status is indicated as 1= ON; 0= OFF.

● Request

Field name	Example	RTU	ASCII	ASCII (bus line)
Start of Frame	-	t1-t2-t3	“,”	0x3A
Slave Address	0x07	0x07	“07”	0x30, 0x37
Function Code	0x02	0x02	“02”	0x30, 0x32
Starting Address Hi	0x00	0x00	“00”	0x30, 0x30
Starting Address Lo	0x00	0x00	“00”	0x30, 0x30
Quantity of Inputs Hi	0x00	0x00	“00”	0x30, 0x30
Quantity of Inputs Lo	0x0A	0x0A	“0A”	0x30, 0x41
Error Check (CRC/LRC)	-	0xF8, 0x6B	“ED”	0x45, 0x44
End of Frame	-	t1-t2-t3	CR, LF	0x0D, 0xA

● Response

Field name	Example	RTU	ASCII	ASCII (bus line)
Start of Frame	-	t1-t2-t3	“,”	0x3A
Slave Address	0x07	0x07	“07”	0x30, 0x37
Function Code	0x02	0x02	“02”	0x30, 0x32
Byte Count	0x02	0x02	“02”	0x30, 0x32
Input Status	0x80	0x80	“80”	0x38, 0x30
Input Status	0x00	0x00	“00”	0x30, 0x30
Error Check (CRC/LRC)	-	0x50, 0x78	“75”	0x37, 0x35
End of Frame	-	t1-t2-t3	CR, LF	0x0D, 0xA

- In case of address 0x0015~0x0000 output bit value: 00000000_10000000.

6.2.3. 3 (0x03) Read Holding Registers

This function code is used to read the contents of a contiguous block of holding registers in a remote device. The Request PDU specifies the starting register address and the number of registers.

The register data in the response message are packed as two bytes per register, with the binary contents right justified within each byte. For each register, the first byte contains the high order bits and the second contains the low order bits.

● Request

Field name	Example	RTU	ASCII	ASCII (bus line)
Start of Frame	-	t1-t2-t3	“,”	0x3A
Slave Address	0x07	0x07	“07”	0x30, 0x37
Function Code	0x03	0x03	“03”	0x30, 0x33
Starting Address Hi	0x08	0x08	“08”	0x30, 0x38
Starting Address Lo	0x00	0x00	“00”	0x30, 0x30
Quantity of Register Hi	0x00	0x00	“00”	0x30, 0x30
Quantity of Register Lo	0x02	0x02	“02”	0x30, 0x32
Error Check (CRC/LRC)	-	0xC6, 0x0D	“EC”	0x45, 0x43
End of Frame	-	t1-t2-t3	CR, LF	0x0D, 0xA

● Response

Field name	Example	RTU	ASCII	ASCII (bus line)
Start of Frame	-	t1-t2-t3	“,”	0x3A
Slave Address	0x07	0x07	“07”	0x30, 0x37
Function Code	0x03	0x03	“03”	0x30, 0x33
Byte Count	0x04	0x04	“04”	0x30, 0x34
Output Register #0 Hi	0x11	0x11	“11”	0x31, 0x31
Output Register #0 Lo	0x22	0x22	“22”	0x32, 0x32
Output Register #1 Hi	0x33	0x33	“33”	0x33, 0x33
Output Register #1 Lo	0x44	0x44	“44”	0x34, 0x34
Error Check (CRC/LRC)	-	0x2D, 0xC6	“38”	0x33, 0x38
End of Frame	-	t1-t2-t3	CR, LF	0x0D, 0xA

- In case of address 0x0800, 0x0801 output register value: 0x1122, 0x3344.

6.2.4. 4 (0x04) Read Input Registers

This function code is used to read from 1 to approx. 125 contiguous input registers in a remote device. The Request PDU specifies the starting register address and the number of registers. The register data in the response message are packed as two bytes per register, with the binary contents right justified within each byte. For each register, the first byte contains the high order bits and the second contains the low order bits.

● Request

Field name	Example	RTU	ASCII	ASCII (bus line)
Start of Frame	-	t1-t2-t3	“;”	0x3A
Slave Address	0x07	0x07	“07”	0x30, 0x37
Function Code	0x04	0x04	“04”	0x30, 0x34
Starting Address Hi	0x00	0x00	“00”	0x30, 0x30
Starting Address Lo	0x00	0x00	“00”	0x30, 0x30
Quantity of Register Hi	0x00	0x00	“00”	0x30, 0x30
Quantity of Register Lo	0x02	0x02	“02”	0x30, 0x32
Error Check (CRC/LRC)	-	0x71, 0xAD	“F3”	0x46, 0x33
End of Frame	-	t1-t2-t3	CR, LF	0x0D, 0xA

● Response

Field name	Example	RTU	ASCII	ASCII (bus line)
Start of Frame	-	t1-t2-t3	“;”	0x3A
Slave Address	0x07	0x07	“07”	0x30, 0x37
Function Code	0x04	0x04	“04”	0x30, 0x34
Byte Count	0x04	0x04	“04”	0x30, 0x34
Input Register #0 Hi	0x00	0x00	“00”	0x30, 0x30
Input Register #0 Lo	0x80	0x80	“80”	0x38, 0x30
Input Register #1 Hi	0x00	0x00	“00”	0x30, 0x30
Input Register #1 Lo	0x00	0x00	“00”	0x30, 0x30
Error Check (CRC/LRC)	-	0x9C, 0x6C	“71”	0x37, 0x31
End of Frame	-	t1-t2-t3	CR, LF	0x0D, 0xA

- In case of address 0x0000, 0x0001 input register value: 0x0080, 0x0000.

6.2.5. 5 (0x05) Write Single Coil

This function code is used to write a single output to either ON or OFF in a remote device. The requested ON/OFF state is specified by a constant in the request data field. A value of FF 00 hex requests the output to be ON. A value of 00 00 requests it to be OFF. All other values are illegal and will not affect the output.

● Request

Field name	Example	RTU	ASCII	ASCII (bus line)
Start of Frame	-	t1-t2-t3	“,”	0x3A
Slave Address	0x07	0x07	“07”	0x30, 0x37
Function Code	0x05	0x05	“05”	0x30, 0x35
Starting Address Hi	0x10	0x10	“10”	0x31, 0x30
Starting Address Lo	0x01	0x01	“01”	0x30, 0x31
Quantity of Outputs Hi	0xFF	0xFF	“FF”	0x46, 0x46
Quantity of Outputs Lo	0x00	0x00	“00”	0x30, 0x30
Error Check (CRC/LRC)	-	0xD9, 0x5C	“E4”	0x45, 0x34
End of Frame	-	t1-t2-t3	CR, LF	0x0D, 0xA

● Response

Field name	Example	RTU	ASCII	ASCII (bus line)
Start of Frame	-	t1-t2-t3	“,”	0x3A
Slave Address	0x07	0x07	“07”	0x30, 0x37
Function Code	0x05	0x05	“05”	0x30, 0x35
Output Address Hi	0x10	0x10	“10”	0x31, 0x30
Output Address Lo	0x01	0x01	“01”	0x30, 0x31
Output Value Hi	0xFF	0xFF	“FF”	0x46, 0x46
Output Value Lo	0x00	0x00	“00”	0x30, 0x30
Error Check (CRC/LRC)	-	0xD9, 0x5C	“E4”	0x45, 0x34
End of Frame	-	t1-t2-t3	CR, LF	0x0D, 0xA

- Output bit of address 0x1001 turns ON.

6.2.6. 6 (0x06) Write Single Register

This function code is used to write a single holding register in a remote device. Therefore register numbered 1 is addressed as 0. The normal response is an echo of the request, returned after the register contents have been written.

● Request

Field name	Example	RTU	ASCII	ASCII (bus line)
Start of Frame	-	t1-t2-t3	“,”	0x3A
Slave Address	0x07	0x07	“07”	0x30, 0x37
Function Code	0x06	0x06	“06”	0x30, 0x36
Starting Address Hi	0x08	0x08	“08”	0x30, 0x38
Starting Address Lo	0x00	0x00	“00”	0x30, 0x30
Quantity of Outputs Hi	0x11	0x11	“11”	0x31, 0x31
Quantity of Outputs Lo	0x22	0x22	“22”	0x32, 0x32
Error Check (CRC/LRC)	-	0x07, 0x85	“B8”	0x42, 0x38
End of Frame	-	t1-t2-t3	CR, LF	0x0D, 0xA

● Response

Field name	Example	RTU	ASCII	ASCII (bus line)
Start of Frame	-	t1-t2-t3	“,”	0x3A
Slave Address	0x07	0x07	“07”	0x30, 0x37
Function Code	0x06	0x06	“06”	0x30, 0x36
Output Address Hi	0x08	0x08	“08”	0x31, 0x38
Output Address Lo	0x00	0x00	“00”	0x30, 0x30
Output Value Hi	0x11	0x11	“11”	0x31, 0x31
Output Value Lo	0x22	0x22	“22”	0x32, 0x32
Error Check (CRC/LRC)	-	0x07, 0x85	“B8”	0x42, 0x38
End of Frame	-	t1-t2-t3	CR, LF	0x0D, 0xA

- In case of address 0x0800 outputs register value: 0x0000 changes to 0x1122.

6.2.7. 8 (0x08) Diagnostics

MODBUS function code 08 provides a series of tests for checking the communication system between a client (Master) device and a server (Slave), or for checking various internal error conditions within a server.

The function uses a two-byte sub-function code field in the query to define the type of test to be performed. The server echoes both the function code and sub-function code in a normal response. Some of the diagnostics cause data to be returned from the remote device in the data field of a normal response.

● **Request**

Field name	Example	RTU	ASCII	ASCII (bus line)
Start of Frame	-	t1-t2-t3	“,”	0x3A
Slave Address	0x07	0x07	“07”	0x30, 0x37
Function Code	0x08	0x08	“08”	0x30, 0x38
Sub-Function Hi	0x00	0x00	“00”	0x30, 0x30
Sub-Function Lo	0x00	0x00	“00”	0x30, 0x30
Data Hi	0x11	0x11	“11”	0x31, 0x31
Data Lo	0x22	0x22	“22”	0x32, 0x32
Error Check (CRC/LRC)	-	0x6C, 0x24	“BE”	0x42, 0x45
End of Frame	-	t1-t2-t3	CR, LF	0x0D, 0xA

● **Response**

Field name	Example	RTU	ASCII	ASCII (bus line)
Start of Frame	-	t1-t2-t3	“,”	0x3A
Slave Address	0x07	0x07	“07”	0x30, 0x37
Function Code	0x08	0x08	“08”	0x30, 0x38
Sub-Function Hi	0x00	0x00	“00”	0x30, 0x30
Sub-Function Lo	0x00	0x00	“00”	0x30, 0x30
Data Hi	0x11	0x11	“11”	0x31, 0x31
Data Lo	0x22	0x22	“22”	0x32, 0x32
Error Check (CRC/LRC)	-	0x6C, 0x24	“BE”	0x42, 0x45
End of Frame	-	t1-t2-t3	CR, LF	0x0D, 0xA

✓ **Sub-function 0x0000(0) Return Query Data**

The data passed in the request data field is to be returned (looped back) in the response.

The entire response message should be identical to the request.

Sub-function	Data Field (Request)	Data Field (Response)	Description
0x0000(0)	Any	Echo Request Data	

✓ **Sub-function 0x0001(1) Restart Communications Option**

The remote device could be initialized and restarted, and all of its communications event counters are cleared. Especially, data field 0x55AA makes the remote device to restart with factory default setup of EEPROM.

Sub-function	Data Field (Request)	Data Field (Response)	Description
0x0001(1)	0x0000, 0xFF00	Echo Request Data	Reset
0x0001(1)	0x55AA	Echo Request Data	Reset with Factory Default*

*All expansion slot configuration parameters are cleared.

✓ **Sub-function 0x000A(10) Clear Counters and Diagnostic Register**

The goal is to clear all counters and the diagnostic register. Counters are also cleared upon power-up.

Sub-function	Data Field (Request)	Data Field (Response)	Description
0x000A(10)	0x0000	Echo Request Data	

✓ **Sub-function 0x000B(11) Return Bus Message Count**

The response data field returns the quantity of messages that the remote device has detected on the communications system since its last restart, clear counters operation, or power-up.

Sub-function	Data Field (Request)	Data Field (Response)	Description
0x000B(11)	0x0000	Total Message Count	

✓ **Sub-function 0x000C(12) Return Bus Communication Error Count**

The response data field returns the quantity of CRC errors encountered by the remote device since its last restart, clear counters operation, or power-up.

Sub-function	Data Field (Request)	Data Field (Response)	Description
0x000C(12)	0x0000	CRC Error Count	

✓ **Sub-function 0x000D(13) Return Bus Exception Error Count**

The response data field returns the quantity of MODBUS exception responses returned by the remote device since its last restart, clear counters operation, or power-up.

Exception responses are described and listed in section 6.2.11.

Sub-function	Data Field (Request)	Data Field (Response)	Description
0x000D(13)	0x0000	Exception Error Count	

✓ **Sub-function 0x000E(14) Return Slave Message Count**

The response data field returns the quantity of messages addressed to the remote device, or broadcast, that the remote device has processed since its last restart, clear counters operation, or power-up.

Sub-function	Data Field (Request)	Data Field (Response)	Description
0x000E(14)	0x0000	Slave Message Count	

✓ **Sub-function 0x000F(15) Return Slave No Response Count**

The response data field returns the quantity of messages addressed to the remote device for which it has returned no response (neither a normal response nor an exception response), since its last restart, clear counters operation, or power-up.

Sub-function	Data Field (Request)	Data Field (Response)	Description
0x000F(15)	0x0000	Slave No Response Count	

✓ **Sub-function 0x0064(100) Return Slave MODBUS, FnBus Status**

The response data field returns the status of MODBUS and FnBus addressed to the remote device.

This status values are identical with status 1 word of input process image. Refer to 5.3.1.

Sub-function	Data Field (Request)	Data Field (Response)	Description
0x0064(100)	0x0000	MODBUS, FnBus Status	Same as status 1 word

✓ **Sub-function 0x0065(101) Return Slave MODBUS, Error Count**

The response data field returns the quantity of watchdog error addressed to the remote device since its last restart, clear counters operation, or power-up.

Sub-function	Data Field (Request)	Data Field (Response)	Description
0x0065(101)	0x0000	Watchdog Error Count	

✓ **Sub-function 0x0066(102) Change Slave IO Output Status**

The sub-function with data fields is to clear watchdog counter and change IO output status. This may be used to simulate clear output and fault output.

Sub-function	Data Field (Request)	Data Field (Response)	Description
0x0066(102)	0x0000	Echo Request Data	Ready output, Automatically turns Normal output
0x0066(102)	0x0001, 0x0002, 0x0003	Echo Request Data	Clear output
0x0066(102)	0x0004	Echo Request Data	Normal output
0x0066(102)	0x0005, 0x0006, 0x0007	Echo Request Data	Fault output

6.2.8. 15 (0x0F) Write Multiple Coils

This function code is used to force each coil in a sequence of coils to either ON or OFF in a remote device. The Request PDU specifies the coil references to be forced. Coils are addressed starting at zero. A logical '1' in a bit position of the field requests the corresponding output to be ON. A logical '0' requests it to be OFF. The normal response returns the function code, starting address, and quantity of coils forced.

● Request

Field name	Example	RTU	ASCII	ASCII (bus line)
Start of Frame	-	t1-t2-t3	“,”	0x3A
Slave Address	0x07	0x07	“07”	0x30, 0x37
Function Code	0x0F	0x0F	“0F”	0x30, 0x46
Starting Address Hi	0x10	0x10	“10”	0x31, 0x30
Starting Address Lo	0x00	0x00	“00”	0x30, 0x30
Quantity of Outputs Hi	0x00	0x00	“00”	0x30, 0x30
Quantity of Outputs Lo	0x0A	0x0A	“0A”	0x30, 0x41
Byte Count	0x02	0x02	“02”	0x30, 0x32
Output Value #0	0x55	0x55	“55”	0x35, 0x35
Output Value #1	0x01	0x01	“01”	0x30, 0x31
Error Check (CRC/LRC)	-	0x21, 0XC9	“78”	0x37, 0x38
End of Frame	-	t1-t2-t3	CR, LF	0x0D, 0xA

● Response

Field name	Example	RTU	ASCII	ASCII (bus line)
Start of Frame	-	t1-t2-t3	“,”	0x3A
Slave Address	0x07	0x07	“07”	0x30, 0x37
Function Code	0x0F	0x0F	“0F”	0x30, 0x46
Starting Address Hi	0x10	0x10	“10”	0x31, 0x30
Starting Address Lo	0x00	0x00	“00”	0x30, 0x30
Quantity of Outputs Hi	0x00	0x00	“00”	0x30, 0x30
Quantity of Outputs Lo	0x0A	0x0A	“0A”	0x30, 0x41
Error Check (CRC/LRC)	-	0xD1, 0x6A	“D0”	0x44, 0x30
End of Frame	-	t1-t2-t3	CR, LF	0x0D, 0xA

- In case of address 0x1015~0x1000 output bit value: 00000000_00000000 changes to 00000001_01010101.

6.2.9. 16 (0x10) Write Multiple Registers

This function code is used to write a block of contiguous registers (1 to approx. 120 registers) in a remote device. The requested written values are specified in the request data field. Data is packed as two bytes per register. The normal response returns the function code, starting address, and quantity of registers written.

● Request

Field name	Example	RTU	ASCII	ASCII (bus line)
Start of Frame	-	t1-t2-t3	“,”	0x3A
Slave Address	0x07	0x07	“07”	0x30, 0x37
Function Code	0x0F	0x0F	“0F”	0x30, 0x46
Starting Address Hi	0x08	0x08	“08”	0x30, 0x38
Starting Address Lo	0x00	0x00	“00”	0x30, 0x30
Quantity of Registers Hi	0x00	0x00	“00”	0x30, 0x30
Quantity of Registers Lo	0x02	0x02	“02”	0x30, 0x32
Byte Count	0x04	0x04	“04”	0x30, 0x34
Register Value #0 Hi	0x11	0x11	“11”	0x31, 0x31
Register Value #0 Lo	0x22	0x22	“22”	0x32, 0x32
Register Value #1 Hi	0x33	0x33	“33”	0x33, 0x33
Register Value #1 Lo	0x44	0x44	“44”	0x34, 0x34
Error Check (CRC/LRC)	-	0x3B, 0x12	“31”	0x33, 0x31
End of Frame	-	t1-t2-t3	CR, LF	0x0D, 0xA

● Response

Field name	Example	RTU	ASCII	ASCII (bus line)
Start of Frame	-	t1-t2-t3	“,”	0x3A
Slave Address	0x07	0x07	“07”	0x30, 0x37
Function Code	0x0F	0x0F	“0F”	0x30, 0x46
Starting Address Hi	0x08	0x08	“08”	0x30, 0x38
Starting Address Lo	0x00	0x00	“00”	0x30, 0x30
Quantity of Outputs Hi	0x00	0x00	“00”	0x30, 0x30
Quantity of Outputs Lo	0x02	0x02	“02”	0x30, 0x32
Error Check (CRC/LRC)	-	0x43, 0xCE	“DF”	0x44, 0x46
End of Frame	-	t1-t2-t3	CR, LF	0x0D, 0xA

- In case of address 0x0800, 0x0801 output register value: 0x0000, 0x0000 changes to 0x1122, 0x3344.

6.2.10. 23 (0x17) Read/Write Multiple Registers

This function code performs a combination of one read operation and one write operation in a single MODBUS transaction. The write operation is performed before the read. The request specifies the starting address and number of holding registers to be read as well as the starting address, number of holding registers, and the data to be written. The byte count specifies the number of bytes to follow in the write data field.

The normal response contains the data from the group of registers that were read. The byte count field specifies the quantity of bytes to follow in the read data field.

● Request

Field name	Example	RTU	ASCII	ASCII (bus line)
Start of Frame	-	t1-t2-t3	“,”	0x3A
Slave Address	0x07	0x07	“07”	0x30, 0x37
Function Code	0x17	0x17	“17”	0x31, 0x37
Read Starting Address Hi	0x08	0x08	“08”	0x30, 0x38
Read Starting Address Lo	0x00	0x00	“00”	0x30, 0x30
Quantity of Read Hi	0x00	0x00	“00”	0x30, 0x30
Quantity of Read Lo	0x02	0x02	“02”	0x30, 0x32
Write Starting Address Hi	0x08	0x08	“08”	0x30, 0x38
Write Starting Address Lo	0x00	0x00	“00”	0x30, 0x30
Quantity of Write Hi	0x00	0x00	“00”	0x30, 0x30
Quantity of Write Lo	0x02	0x02	“02”	0x30, 0x32
Byte Count	0x04	0x04	“04”	0x30, 0x34
Write Reg. Value #0 Hi	0x11	0x11	“11”	0x31, 0x31
Write Reg. Value #0 Lo	0x22	0x22	“22”	0x32, 0x32
Write Reg. Value #1 Hi	0x33	0x33	“33”	0x33, 0x33
Write Reg. Value #1 Lo	0x44	0x44	“44”	0x34, 0x34
Error Check (CRC/LRC)	-	0x88, 0x3F	“20”	0x32, 0x30
End of Frame	-	t1-t2-t3	CR, LF	0x0D, 0xA

● Response

Field name	Example	RTU	ASCII	ASCII (bus line)
Start of Frame	-	t1-t2-t3	“,”	0x3A
Slave Address	0x07	0x07	“07”	0x30, 0x37
Function Code	0x17	0x17	“17”	0x31, 0x37
Byte Count	0x04	0x04	“04”	0x30, 0x34
Write Reg. Value #0 Hi	0x11	0x11	“11”	0x31, 0x31
Write Reg. Value #0 Lo	0x22	0x22	“22”	0x32, 0x32
Write Reg. Value #1 Hi	0x33	0x33	“33”	0x33, 0x33
Write Reg. Value #1 Lo	0x44	0x44	“44”	0x34, 0x34
Error Check (CRC/LRC)	-	0x2E, 0xD2	“34”	0x33, 0x34
End of Frame	-	t1-t2-t3	CR, LF	0x0D, 0xA

- In case of address 0x0800, 0x0801 output register value: 0x0000, 0x0000 changes to 0x1122, 0x3344.

6.2.11. Error Response

In an exception response, the server sets the MSB of the function code to 1. This makes the function code value in an exception response exactly 80 hexadecimal higher than the value would be for a normal response.

● Exception Response Example

Field name	Example	RTU	ASCII	ASCII (bus line)
Start of Frame	-	t1-t2-t3	“,”	0x3A
Slave Address	0x07	0x07	“07”	0x30, 0x37
Function Code	0x81	0x81	“81”	0x38, 0x31
Exception Code	0x02	0x02	“02”	0x30, 0x32
Error Check (CRC/LRC)	-	0x22, 0xC0	“76”	0x37, 0x36
End of Frame	-	t1-t2-t3	CR, LF	0x0D, 0xA

● Exception Codes

Exception Code	Name	Description
01	Illegal Function	The function code received in the query is not an allowable action for the server (or slave).
02	Illegal Data Address	The data address received in the query is not an allowable address for the server (or slave).
03	Illegal Data Value	A value contained in the query data field is not an allowable value for server (or slave).
04	Slave Device Failure	An unrecoverable error occurred while the server (or slave) was attempting to perform the requested action.
05	Acknowledge	The server (or slave) has accepted the request and is processing it, but a long duration of time will be required to do so.
06	Slave Device Busy	Specialized use in conjunction with programming commands. The server (or slave) is engaged in processing a long-duration program command. The client (or master) should retransmit the message later when the server (or slave) is free.
08	Memory Parity Error	The server (or slave) attempted to read record file, but detected a parity error in the memory. The client (or master) can retry the request, but service may be required on the server (or slave) device.
0A	Gateway Path Unavailable	Specialized use in conjunction with gateways, indicates that the gateway was unable to allocate an internal communication path from the input port to the output port for processing the request.

- NA-9171, NA-9173 response exception code 01, 02, 03, 04 and 06.

6.3. MODBUS Special Register Map

The special register map can be accessed by function code 3, 4, 6 and 16. Also the special register map must be accessed by read/write of every each address (one address).

6.3.1. Adapter Identification Special Register (0x1000, 4096)

Address	Access	Type, Size	Description
0x1000(4096)	Read	1 word	Vendor ID = 0x02E5 (741), Crevis. Co., Ltd.
0x1001(4097)	Read	1 word	Device type = 0x000C, Network Adapter
0x1002(4098)	Read	1 word	Product code. 0x0300 (NA-9171, MODBUS/RS-232) 0x0301 (NA-9173, MODBUS/RS-485)
0x1003(4099)	Read	1 word	Firmware revision, if 0x0101, revision 1.01
0x1004(4100)	Read	2 words	Product unique serial number
0x1005(4101)	Read	String upto 34bytes	Product name string First 1 word is length of valid character string Example) response as following "00 15 4E 41 39 31 37 33 5F 4D 4F 44 42 55 53 5F 41 64 61 70 74 65 72 00 00 00" Valid character size = 0x0015 =21 characters "NA9173_MODBUS_Adapter"
0x1006(4102)	Read	1 word	Sum check of EEPROM
0x1010(4112)	Read	2 words	Firmware release date
0x1011(4113)	Read	2 words	Product manufacturing inspection date
0x1012(4114)	Read	String upto 34bytes	Vendor name string First 1 word is length of valid character string.
0x101E(4126)	Read	7 words - 1 word - 1 word - 1 word - 1 word - 1 word - 2 words	Composite Id of following address 0x1100(4352), Rotary switch value, Slave Node Id. 0x1000(4096), Vendor ID 0x1001(4097), Device type 0x1002(4098), Product code 0x1003(4099), Firmware revision 0x1004(4100), Product serial number

- String Type consists of valid string length (first 1 word) and array of characters.

6.3.2. Adapter Watchdog Time, other Time Special Register (0x1020, 4128)

A watchdog timer can be configured for timeout periods up to 65535(1unit=100msec). The Watchdog timer will timeout (timer decreased, reached 0) if MODBUS operation to the slave node does not occur over the configured watchdog value, then the slave adapter forces that slot output value is automatically set to user-configured fault actions and values.

Address	Access	Type, Size	Description
0x1020(4128)	Read/Write	1 word	Watchdog time value 16bit unsigned. The time value is represented by multiples of 100msec. The default value is 50 (50*100msec=5sec). A changing of watchdog time value resets watchdog error.
0x1021(4129)	Read	1 word	Watchdog time remain value This value decreases every 100msec
0x1022(4130)	Read	1 word	Watchdog error counter, it is cleared by writing address 0x1020
0x1023(4131)	Read/Write	1 word	Enable/disable auto recovery Watchdog error when receiving new frame. 0: Disable, 1: Enable (default). Its value is stored in EEPROM.
0x1024(4132)	Read/Write	1 word	Transmission response delay time. The value can be set 16bit unsigned (1msec unit). The default value is 0 (no delay).
0x1025(4133)	Read/Write	1 word	Valid byte-byte time gap in ASCII mode. (1msec unit) In ASCII mode byte-byte time gap is over setting value during receiving frame, this frame will be cancelled (dropped).
0x1028(4136)	Read	2 words	IO update time, main loop time. (100usec unit)

6.3.3. Adapter Information Special Register (0x1100, 4352)

Address	Access	Type, Size	Description
0x1100(4352)	Read/Write	1 word	Hi byte is two rotary switch values; low byte is current slave node address. MODBUS slave node address. If two rotary switches value are 0, the slave node address is assigned with last valid address and can be changed by software (1~247).
0x1101(4353)	Read	1 word	Hi byte is a current dip switch value; low byte is used current setup value.
0x1102(4354)	Read	1 word	Start address of input image word register. =0x0000
0x1103(4355)	Read	1 word	Start address of output image word register. =0x0800
0x1104(4356)	Read	1 word	Size of input image word register.
0x1105(4357)	Read	1 word	Size of output image word register.
0x1106(4358)	Read	1 word	Start address of input image bit. = 0x0000
0x1107(4359)	Read	1 word	Start address of output image bit. =0x1000
0x1108(4360)	Read	1 word	Size of input image bit.
0x1109(4361)	Read	1 word	Size of output image bit.
0x110E(4366)	Read	upto 33 word	Expansion slot's ST-number including NA. First 1word is adapter's number, if NA-9173, then 0x9173
0x1110(4368)	Read	1 word	Number of expansion slot
0x1111(4369)	Read	1 word	Number of active slot
0x1112(4370)	Read	1 word	Number of inactive slot
0x1113(4371)	Read	upto 33 word	Expansion slot Module Id. Refer to Appendix A.1 Product List. First 1word is adapter's module id.
0x1114(4372)*	Read/Write	1 word	Input process image mode. The default value is 2. Valid value range is from 0 to 3. Refer to 5.3.1.
0x1115(4373)*	Read/Write	1 word	Output process image mode. The default value is 0. Valid value range is from 0 to 1. Refer to 5.3.2.
0x1116(4374)**	Read/Write	2 words	Inactive slot list, The corresponding bit represents slot position. 0: Active slot, 1: Inactive slot. Ex) if value is 0x0001, 0x8000, then slot#1,#32 are inactive slots
0x1117(4375)	Read	2 words	Live slot list. , The corresponding bit represents slot position. 1: live slot, 0: not live slot
0x1118(4376)	Read	2 words	Alarm slot list. The corresponding bit represents slot position. 1: Alarm slot, 0: Normal slot
0x1119(4377)	Read	1 word	Hi byte is MODBUS status, low byte is FnBus status. Refer to 5.3.1.
0x111A(4378)	Write	1 word	Reserved. Adapter Scan command.
0x111B(4379)	Read/Write	1 word	Reserved. IO State machine.
0x111C(4380)	Read	2 words	Reserved. Runtime fault code.
0x111D(4381)	Read	1 word	Adapter FnBus Revision. If 0x013C, FnBus Revision is 1.60
0x111E(4382)	Read	1 word	Reserved. Adapter IO identification vendor code.

*, ** After the system is reset, the new "Set Value" action is applied.

** If the slot location is changed, set default value automatically (all expansion slots are live).

6.3.4. Expansion Slot Information Special Register (0x2000, 8192)

Each expansion slot has 0x20(32) address offset and same information structure.

Slot#1	0x2000(8192) ~0x201F (8223)	Slot#17	0x2200(8704) ~0x221F (8735)
Slot#2	0x2020(8224) ~0x203F (8255)	Slot#18	0x2220(8736) ~0x223F (8767)
Slot#3	0x2040(8256) ~0x205F (8287)	Slot#19	0x2240(8768) ~0x225F (8799)
Slot#4	0x2060(8288) ~0x207F (8319)	Slot#20	0x2260(8800) ~0x227F (8831)
Slot#5	0x2080(8320) ~0x209F (8351)	Slot#21	0x2280(8832) ~0x229F (8863)
Slot#6	0x20A0 (8352) ~0x20BF (8383)	Slot#22	0x22A0 (8864) ~0x22BF (8895)
Slot#7	0x20C0 (8384) ~0x20DF (8415)	Slot#23	0x22C0 (8896) ~0x22DF (8927)
Slot#8	0x20E0 (8416) ~0x20FF (8447)	Slot#24	0x22E0 (8928) ~0x22FF (8959)
Slot#9	0x2100(8448) ~0x211F (8479)	Slot#25	0x2300(8960) ~0x231F (8991)
Slot#10	0x2120(8480) ~0x213F (8511)	Slot#26	0x2320(8992) ~0x233F (9023)
Slot#11	0x2140(8512) ~0x215F (8543)	Slot#27	0x2340(9024) ~0x235F (9055)
Slot#12	0x2160(8544) ~0x217F (8575)	Slot#29	0x2360(9056) ~0x237F (9087)
Slot#13	0x2180(8576) ~0x219F (8607)	Slot#20	0x2380(9088) ~0x239F (9119)
Slot#14	0x21A0 (8608) ~0x21BF (8639)	Slot#30	0x23A0 (9120) ~0x23BF (9151)
Slot#15	0x21C0 (8640) ~0x21DF (8671)	Slot#31	0x23C0 (9152) ~0x23DF (9183)
Slot#16	0x21E0 (8672) ~0x21FF (8703)	Slot#32	0x23E0 (9184) ~0x23FF (9215)

Address Offset	Expansion Slot#1	Expansion Slot#2	Expansion Slot#3	Expansion Slot#31	Expansion Slot#32
+ 0x00(+0)	0x2000(8192)	0x2020(8224)	0x2040(8256)	0x23C0(9152)	0x23E0(9184)
+ 0x01(+1)	0x2001(8193)	0x2021(8225)	0x2041(8257)	0x23C1(9153)	0x23E1(9185)
+ 0x02(+2)	0x2002(8194)	0x2022(8226)	0x2042(8258)	0x23C2(9154)	0x23E2(9186)
+ 0x03(+3)	0x2003(8195)	0x2023(8227)	0x2043(8259)	0x23C3(9155)	0x23E3(9187)
+ 0x04(+4)	0x2004(8196)	0x2024(8228)	0x2044(8260)	0x23C4(9156)	0x23E4(9188)
+ 0x05(+5)	0x2005(8197)	0x2025(8229)	0x2045(8261)	0x23C5(9157)	0x23E5(9189)
+ 0x06(+6)	0x2006(8198)	0x2026(8230)	0x2046(8262)	0x23C6(9158)	0x23E6(9190)
+ 0x07(+7)	0x2007(8199)	0x2027(8231)	0x2047(8263)	0x23C7(9159)	0x23E7(9191)
+ 0x08(+8)	0x2008(8200)	0x2028(8232)	0x2048(8264)	0x23C8(9160)	0x23E8(9192)
+ 0x09(+9)	0x2009(8201)	0x2029(8233)	0x2049(8265)	0x23C9(9161)	0x23E9(9193)
+ 0x0A(+10)	0x200A(8202)	0x202A(8234)	0x204A(8266)	0x23CA(9162)	0x23EA(9194)
+ 0x0B(+11)	0x200B(8203)	0x202B(8235)	0x204B(8267)	0x23CB(9163)	0x23EB(9195)
+ 0x0C(+12)	0x200C(8204)	0x202C(8236)	0x204C(8268)	0x23CC(9164)	0x23EC(9196)
+ 0x0D(+13)	0x200D(8205)	0x202D(8237)	0x204D(8269)	0x23CD(9165)	0x23ED(9197)
+ 0x0E(+14)	0x200E(8206)	0x202E(8238)	0x204E(8270)	0x23CE(9166)	0x23EE(9198)
+ 0x0F(+15)	0x200F(8207)	0x202F(8239)	0x204F(8271)	0x23CF(9167)	0x23EF(9199)
+ 0x10(+16)	0x2010(8208)	0x2030(8240)	0x2050(8272)	0x23D0(9168)	0x23F0(9200)
+ 0x11(+17)	0x2011(8209)	0x2031(8241)	0x2051(8273)	0x23D1(9169)	0x23F1(9201)
+ 0x12(+18)	0x2012(8210)	0x2032(8242)	0x2052(8274)	0x23D2(9170)	0x23F2(9202)
+ 0x13(+19)	0x2013(8211)	0x2033(8243)	0x2053(8275)	0x23D3(9171)	0x23F3(9203)
+ 0x14(+20)	0x2014(8212)	0x2034(8244)	0x2054(8276)	0x23D4(9172)	0x23F4(9204)
+ 0x15(+21)	0x2015(8213)	0x2035(8245)	0x2055(8277)	0x23D5(9173)	0x23F5(9205)
+ 0x16(+22)	0x2016(8214)	0x2036(8246)	0x2056(8278)	0x23D6(9174)	0x23F6(9206)
+ 0x17(+23)	0x2017(8215)	0x2037(8247)	0x2057(8279)	0x23D7(9175)	0x23F7(9207)
+ 0x18(+24)	0x2018(8216)	0x2038(8248)	0x2058(8280)	0x23D8(9176)	0x23F8(9208)
+ 0x19(+25)	0x2019(8217)	0x2039(8249)	0x2059(8281)	0x23D9(9177)	0x23F9(9209)
+ 0x1A(+26)	0x201A(8218)	0x203A(8250)	0x205A(8282)	0x23DA(9178)	0x23FA(9210)
+ 0x1B(+27)	0x201B(8219)	0x203B(8251)	0x205B(8283)	0x23DB(9179)	0x23FB(9211)
+ 0x1C(+28)	0x201C(8220)	0x203C(8252)	0x205C(8284)	0x23DC(9180)	0x23FC(9212)

+ 0x1D(+29)	0x201D(8221)	0x203D(8253)	0x205D(8285)	0x23DD(9181)	0x23FD(9213)
+ 0x1E(+30)	0x201E(8222)	0x203E(8254)	0x205E(8286)	0x23DE(9182)	0x23FE(9214)
+ 0x1F(+31)	0x201F(8223)	0x203F(8255)	0x205F(8287)	0x23DF(9183)	0x23FF(9215)

Address	Access	Type, Size	Description
+ 0x00(+0)	Read	1 word	Slot module id. Refer to Appendix A.1 Product List.
+ 0x01(+1)	Read	1 word	Expansion Slot IO code. Refer to Table IO Data Code Format.
+ 0x02(+2)**	Read	1 word	Input start register address of input image word this slot.
+ 0x03(+3)**	Read	1 word	Input word's bit offset of input image word this slot.
+ 0x04(+4)**	Read	1 word	Output start register address of output image word this slot.
+ 0x05(+5)**	Read	1 word	Output word's bit offset of output image word this slot.
+ 0x06(+6)**	Read	1 word	Input bit start address of input image bit this slot.
+ 0x07(+7)**	Read	1 word	Output bit start address of output image bit this slot.
+ 0x08(+8)**	Read	1 word	Size of input bit this slot
+ 0x09(+9)**	Read	1 word	Size of output bit this slot
+ 0x0A(+10)**	Read	n words	Read input data this slot
+ 0x0B(+11)**	Read/Write	n words	Read/write output data this slot
+ 0x0C(+12)*	Read/Write	1 word	Inactive slot, 0x0000:active, 0x0001:inactive
+ 0x0E(+14)	Read	1 word	ST-number, if ST-1324, returns 0x1324
+ 0x0F(+15)	Read	String upto 74 words	First 1word is length of valid character string. If ST-1324, returns "00 21 53 54 2D 31 33 32 34 2C 20 46 6E 49 4F 20 34 20 53 6F 75 72 63 69 6E 67 20 49 6E 20 34 38 56 64 63 00" Valid character size = 0x0021 =33 characters, "ST-1324, FnIO 4 Sourcing In 48Vdc"
+ 0x10(+16)	Read	1 word	Size of configuration parameter byte
+ 0x11(+17)**	Read/Write	n words	Read/write Configuration parameter data, up to 8byte. Refer to document(FnIO_Configuration_Parameter_Memory_Register_Rev1.01) ***
+ 0x12(+18)	Read	1 word	Size of memory byte.
+ 0x13(+19)**	Read/Write	n words	Read/write Memory data. Offset of memory is fixed with 0.
+ 0x14(+20)**	Read/Write	n words	Read/write Memory data. First 2byte of write data is memory offset.
+ 0x15(+21)	Read	2 words	Product code Refer to Appendix A.1 Product List.
+ 0x16(+22)	Read	2 words	Catalog number. Refer to Appendix A.1 Product List.
+ 0x17(+23)	Read	1 word	Firmware Revision
+ 0x18(+24)	Read	1 word	FnBus Revision
+ 0x1A(+26)	Read/Write	n words	Reserved. Read/write expansion class access.
+ 0x1B(+27)	Read/Write	n words	Reserved. Read/write maintenance data access.

* After the system is reset, the new "Set Value" action is applied.

** Nothing of output, input, and memory or configuration parameter corresponding slot returns Exception 02.

*** Slot Configuration parameter saved by internal EEPROM during power cycle until slot position changed.

**** All of output modules and special modules have the slot configuration parameter data. Refer to Document.

(FnIO_Configuration_Parameter_Memory_Register_Rev1.01)

● IO Data Code Format (1 word)

Item	#15	#14	#13	#12	#11	#10	#9	#8	#7	#6	#5	#4	#3	#2	#1	#0	Word
Field	Output IO code								Input IO code								
Field	Date Type				Data Length				Date Type				Data Length				

Example)

ST-3214	0	0	0	0	0	0	0	0	1	0	0	0	0	1	0	0	0x0084
ST-1224	0	0	0	0	0	0	0	0	1	1	0	0	0	1	0	0	0x00C4
ST-1228	0	0	0	0	0	0	0	0	0	1	0	0	0	0	0	1	0x0041
ST-4123	1	0	0	0	0	0	1	0	0	0	0	0	0	0	0	0	0x8200
ST-221F	0	1	0	0	0	0	0	1	0	0	0	0	0	0	0	0	0x4200
ST-2324	1	1	0	0	0	1	0	0	1	1	0	0	0	1	0	0	0xC4C4

Input/output Data Type:

- 0 0: No I/O Data
- 0 1: Byte Data
- 1 0: Word Data
- 1 1: Bit Data

Input/output Data Length:

- 0 0 0 0 0 0: 0 Bit/Byte/Word
- 0 0 0 0 0 1: 1 Bit/Byte/Word
- 0 0 0 0 1 0: 2 Bit/Byte/Word
- 0 0 0 0 1 1: 3 Bit/Byte/Word
-
- 1 1 1 1 1 1: 63 Bit/Byte/Word

6.4. MODBUS Reference

MODBUS Reference Documents

<http://www.modbus.org>

MODBUS Tools

<http://www.modbustools.com> , MODBUS poll

<http://www.win-tech.com> , MODSCAN32

7. Trouble Shooting

7.1. How to diagnose by LED indicator

LED Status	Cause	Action
All LED turns off	- No power	- Check main power Cable
	- System power is not supplied.	- Contact Sales team and send module for repair.
MOD LED Off	- Power Off	- Check the System Power
MOD LED flashes green	- Device in Standby	- Normal Condition
MOD LED is red	- Wrong address ID - Occurrence critical error in firmware	- Contact Sales team and send module for repair.
MOD LED flashes red	- EEPROM Error	- Check the System Power
I/O LED turns off	- Failure of realization expansion Module - None expansion Module	- Check connector status both NA series and expansion module.
I/O LED flashes red	-Failure of configuration baud rate	- Check communication cable with Master - Check power for master.
	-Failure of initialization I/O	- Use expansion slot up to 32. - Compose that IO total size is not excess. -NA series notice unidentified expansion module ID. Check status of expansion module.
I/O LED is red	-Failure of exchanging I/O data	-Check status of expansion IO connection.
RXD turns off	-No power	-Check the system power
RXD flashes green	-Received the data	-Normal condition
TXD turns off	-No power	-Check the system power
TXD flashes green	-Transmit the data	-Normal condition

7.2. How to diagnose when device couldn't communicate network

Inspection of wrong or omission cable connection.

- Check status of cable connection for each node.
- Check that all color matches between connector and cable.
- Check wire omission.

Terminator resistor

- If terminator resistor is not installed, install terminator resistor
- Check location of terminator resistor

Configuration of Node address

- Check duplication node address.

Configuration of Master

- Check configuration of master
- Check whether to do download or don't
- Check composition is right
- Configuration of communication baud rate
- I/O size
- Configuration of each node

Ground and environment

- Check ground is contacted
- Check environment factor (temperature, humidity, etc.) is in less than regular limit

APPENDIX A

A.1. Product List

No.	ST-Number	Description	ID(hex)	Production Status
Digital Input Module				
	ST-1114	4 Points, Sink(Positive), 5Vdc,	41 00 01	Active
	ST-111F	16 Points, Sink(Positive), 5Vdc,	41 01 19	Active
	ST-1124	4 Points, Source(Negative), 5Vdc,	41 00 02	Active
	ST-112F	16 Points, Source(Negative), 5Vdc,	41 01 1A	Active
	ST-1214	4 Points, Sink(Positive), 12V/24Vdc,	41 00 03	Active
	ST-1218	8 Points, Sink(Positive), 12V/24Vdc,	41 00 07	Active
	ST-121F	16 Points, Sink(Positive), 12V/24Vdc,	41 01 13	Active
	ST-1224	4 Points, Source(Negative), 12V/24Vdc,	41 00 04	Active
	ST-1228	8 Points, Source(Negative), 12V/24Vdc,	41 00 08	Active
	ST-122F	16 Points, Source(Negative), 12V/24Vdc,	41 01 14	Active
	ST-1314	4 Points, Sink(Positive), 48Vdc,	41 00 05	Active
	ST-131F	16 Points, Sink(Positive), 48Vdc,	41 01 17	Active
	ST-1324	4 Points, Source(Negative), 48Vdc,	41 00 06	Active
	ST-132F	16 Points, Source(Negative), 48Vdc,	41 01 18	Active
	ST-1804	4 Points, 110Vac,	41 00 09	Active
	ST-1904	4 Points, 220Vac,	41 00 0A	Active
Digital Output Module				
	ST-2114	4 Points TTL Inverting, 5Vdc/20mA,	81 00 0D	Active
	ST-2124	4 Points TTL Non-Inverting, 5Vdc/20mA,	81 00 0F	Active
	ST-221F	16 Points Sink(Negative Logic), 24Vdc/0.5A,	81 01 15	Active
	ST-222F	16 Points Source(Positive Logic), 24Vdc/0.5A,	81 01 16	Active
	ST-2314	4 Points Sink(Negative Logic), 24Vdc/0.5A,	81 00 0E	Active
	ST-2318	8 Points Sink(Negative Logic), 24Vdc/0.5A,	81 00 11	Active
	ST-2324	4 Points Source(Positive Logic), 24Vdc/0.5A,	81 00 10	Active
	ST-2328	8 Points Source(Positive Logic), 24Vdc/0.5A,	81 00 12	Active
	ST-2414	4 Points Sink(Negative Logic), 24Vdc/0.5A, Diagnostics	81 00 08	Active
	ST-2424	4 Points Source(Positive Logic),24Vdc/0.5A, Diagnostics	C1 00 00 38	Active
	ST-2514	4 Points Sink(Negative Logic), 24Vdc/2A, Diagnostics	C1 00 00 35	Active
	ST-2524	4 Points Source(Positive Logic), 24Vdc/2A, Diagnostics	C1 00 00 36	Active
	ST-2614	4 Points Sink(Negative Logic), 24Vdc/2A,	81 00 3B	Active
	ST-2624	4 Points Source(Positive Logic), 24Vdc/2A,	81 00 3C	Active
	ST-2742	2 Points, 230Vac/2A, 24Vdc/2A, Relay	81 00 0B	Active
	ST-2744	4 Points, 230Vac/2A, 24Vdc/2A, Relay	81 00 51	Active
	ST-2748	8 Points, 230Vac/2A, 24Vdc/2A, Relay	81 00 50	Active

	ST-2792	2 Points, 230Vac/2A, 24Vdc/2A, Relay, Manual/Auto	C1 00 01 BE	Active
	ST-2852	2 Points, 12~125Vac/0.5A, Triac	81 00 0C	Active
	ST-2924	4 Points, 24Vac/2A, 24Vdc/2A, 4 Points/4COM	81 00 C0	NEW
	ST-2944	4 Points, 24Vac/2A, 24Vdc/2A, 1 Points/1COM	81 00 C1	NEW
	ST-2734	4 Points, 24~220Vac,dc/0.5A, 1 Points/1COM	81 00 C2	NEW
Analog Input Module				
	ST-3114	4 Channels, Current, 0~20mA, 12bit	41 43 1C	Active
	ST-3118	8 Channels, Current, 0~20mA, 12bit	41 47 82	Active
	ST-3134	4 Channels, Current, 0~20mA, 14bit	41 43 1E	Active
	ST-3214	4 Channels, Current, 4~20mA, 12bit	41 43 1D	Active
	ST-3218	8 Channels, Current, 4~20mA, 12bit	41 47 83	Active
	ST-3234	4 Channels, Current, 4~20mA, 14bit	41 43 1F	Active
	ST-3274	4 Channels, Current, 4~20mA, 12bit, Sensor Connector	41 43 A3	Active
	ST-3424	4 Channels, Voltage, 0~10Vdc, 12bit	41 43 20	Active
	ST-3428	8 Channels, Voltage, 0~10Vdc, 12bit	41 47 22	Active
	ST-3444	4 Channels, Voltage, 0~10Vdc, 14bit	41 43 22	Active
	ST-3474	4 Channels, Voltage, 0~10Vdc, 12bit, Sensor Connector	41 43 A0	Active
	ST-3524	4 Channels, Voltage, -10Vdc~10Vdc, 12bit	41 43 21	Active
	ST-3544	4 Channels, Voltage, -10Vdc~10Vdc, 14bit	41 43 23	Active
	ST-3624	4 Channels, Voltage, 0~5Vdc, 12bit	41 43 24	Active
	ST-3644	4 Channels, Voltage, 0~5Vdc, 14bit	41 43 25	Active
	ST-3702	2 Channels, RTD, Status	41 41 28	Active
	ST-3704	4 Channels, RTD, Status	41 43 64	Active
	ST-3708	8 Channels, RTD, Status	41 47 65	Active
	ST-3802	2 Channels, TC	41 41 2A	Active
	ST-3804	4 Channels, TC	41 43 66	Active
	ST-3808	8 Channels, TC	41 47 67	Active
Analog Output Module				
	ST-4112	2 Channels, Current, 0~20mA, 12bit	81 41 2C	Active
	ST-4114	4 Channels, Current, 0~20mA, 12bit	81 43 6D	Active
	ST-4212	2 Channels, Current, 4~20mA, 12bit	81 41 2D	Active
	ST-4214	4 Channels, Current, 4~20mA, 12bit	81 43 6E	Active
	ST-4274	4 Channels, Current, 4~20mA, 12bit, Sensor Connector	81 43 B3	Active
	ST-4422	2 Channels, Voltage, 0~10Vdc, 12bit	81 41 2E	Active
	ST-4424	4 Channels, Voltage, 0~10Vdc, 12bit	81 43 6A	Active
	ST-4474	4 Channels, Voltage, 0~10Vdc, 12bit, Sensor Connector	81 43 B0	Active
	ST-4491	1 Channel, Voltage, 0~10Vdc, 12bit, Manual Type	C1 40 41 BF	Active
	ST-4522	2 Channels, Voltage, -10~10Vdc, 12bit	81 41 2F	Active
	ST-4622	2 Channels, Voltage, 0~5Vdc, 12bit	81 41 30	Active
	ST-4911	1 Channel, Current, 0~1A, 12bit	81 40 31	Active

Special Module				
	ST-5101	1 Channel, High Speed Counter, 5V Input	C1 01 05 34	Active
	ST-5111	1 Channel, High Speed Counter, 24V Input	C1 01 05 39	Active
	ST-5112	2 Channel, High Speed Counter, 24V Sink Input	C1 01 07 4D	Active
	ST-5114	4 Channel, High Speed Counter, 24V Sink Input	C1 03 0F 4C	Active
	ST-5211	RS232 Communication, 1Channel, RTS/CTS Flow Control	C1 05 05 42	Active
	ST-5212	RS232 Communication, 2Channel	C1 0B 0B 43	Active
	ST-5221	RS422 Communication, 1Channel	C1 05 05 44	Active
	ST-5231	RS485 Communication, 1Channel	C1 05 05 45	Active
	ST-5232	RS485 Communication, 2Channel	C1 0B 0B 46	Active
	ST-5351	SSI Interface 1CH	C1 01 09 9E	Active
	ST-5422	2 CH PWM output, 1.5A/24Vdc, source	C1 05 01 57	Active
	ST-5442	2 CH PWM output, 0.5A/24Vdc, source	C1 05 01 56	Active
	ST-5444	4 CH PWM output, 0.5A/24Vdc, source	C1 0B 03 54	Active
	ST-5641	1 CH Pulse output, 0.5A/24Vdc, source	C1 05 03 92	Active
	ST-5642	2 CH Pulse output, 0.5A/24Vdc, source	C1 09 07 90	Active
	ST-5651	1 CH Pulse output, RS422	C1 05 03 98	Active
Power Module				
	ST-7408	8 Channels, Shield, ID Type	02 00 E4	Active
	ST-7508	8 Channels, Common, 0Vdc, ID Type	02 00 E5	Active
	ST-7511	1 Channel, Expansion Power, Input 24Vdc, Output 1.0A/5Vdc, ID Type	02 00 E0	Active
	ST-7518	8 Channels, Common, 24Vdc, ID Type	02 00 E6	Active
	ST-7588	8 Channels, Common, 0Vdc and 24Vdc, ID Type	02 00 E7	Active
	ST-7641	1 Channel, Field Distributor, 5Vdc~48Vdc, 110Vac~220Vac, ID Type	02 00 E2	Active

A.2. Glossary

- System Power: The power for starting up CPU.
- Field Power: The power for input and output line.
- Terminator Resistor: Resistor for prevention reflected wave.
- EDS: Electronic Data Sheet.
- sinking: The method of input and output what device does not have power source.
- sourcing: The method of input and output what device have power source.